

have been told the story by W. Ley in 1955\*. This book however, is now out of print and we can only hope that biological scientists — and not these only — of today will take the opportunity of reading the cautionary tale of the rise and fall of one of the most gifted zoologists Austria has produced. Even after 46 years no authority has been able to prove whether Kammerer was quite right or quite wrong. Surely there must be an Institute of Zoology somewhere supplied with sufficient funds and devoted staff to repeat his experiments. That is: if they are repeatable.

E. ELKAN

\*Ley, W. (1955). Salamanders and other wonders. Phoenix House, London.

# BRITISH JOURNAL OF HERPETOLOGY

Vol. 4 No.12

June 1973

Published by  
THE BRITISH HERPETOLOGICAL SOCIETY

## CONTENTS

	PAGE
Removal of a deficient fang mechanism in a captive Puff Adder, <i>Bitis arietans</i> . By J. B. Murphy and J. E. Joy ... ..	314
The use of the macrolide tylosin in the treatment of reptilian respiratory infections. By J. B. Murphy... ..	317
Identification of newt specimens (Urodela, <i>Triturus</i> ) by recording the belly pattern and a description of photographic equipment for such registration. By Torkel Hagstrom ... ..	321
Comments on the age of the frog family Pipidae. By C. J. Goin and Olive B. Goin ... ..	326
Rhythmic activity in ground dwelling Agamid lizard, <i>Sitana ponticeriana</i> Cuvier. By M. V. Subba Rao and B. S. Rajabai ... ..	328
Two observations on learning in anurans. By S. J. Gorzula ... ..	332
Defensive behaviour of a captive colubrid <i>Rhinocheilus lecontei</i> . By S. J. Gorzula ... ..	333
Notes on the reproduction of the Southern smooth Snake ( <i>Coronella girondica</i> ). By D. J. Street ... ..	335
Clay 'nests' of toad tadpoles. By Evzen Opatrny ... ..	338
The conservation of British Amphibians and Reptiles. A policy. By The British Herpetological Conservation Committee ... ..	339
Letters to the Editor ... ..	342
Book Reviews ... ..	343

The British Journal of Herpetology is published twice a year and is issued free to members. Application to purchase copies, and/or for details of membership to the Society should be made to the Hon. Secretary, British Herpetological Society, c/o The Zoological Society of London, Regents Park, London, N.W.1.

Contributions should be addressed to the Editor, Dr. Harold Fox, Department of Zoology, University College, Gower Street, London, W.C.1. Articles should be typed in double spacing on *one side* of the paper only. Figures should be drawn in Indian ink on plain white paper, or preferably Bristol Board and suitably lettered for publication.

Published by the British Herpetological Society and  
Printed by Fox Publications Limited, London, N.7., England

REMOVAL OF A DEFICIENT FANG MECHANISM IN A CAPTIVE  
PUFF ADDER, *Bitis arietans*

By

JAMES B. MURPHY AND J. E. JOY  
Dallas Zoo, Dallas, Texas, 75203. U.S.A.  
(Received 31/7/72)

A young puff adder, *Bitis arietans*, obtained on 14 November, 1966, immediately began to feed on a regular basis. It evidenced steady growth and on 15 January, 1972 weighed 1360g and measured 127 cm. The diet consisted of freshly killed laboratory mice and rats, presented to the snake on endoscopic forceps. In November 1971 it was noticed that a yellowish exudate was forming between the labials. The snake was placed in a clear acrylic plastic tube with one end sealed (Murphy, 1971). On closer examination, it was discovered that a number of replacement fangs had lodged within the vagina dentalis and that they were not being discarded properly. Within the vagina dentalis, a considerable amount of caseous yellow exudate had collected and was beginning to involve the pterygoid teeth. Eight replacement fangs and a copious amount of necrotic tissue and exudate were removed from the sheath. The area was infused with hydrogen peroxide by inserting a 1 cc tuberculin syringe into the sheath opening. Kymar (proteolytic enzyme ointment) was packed into the sheath and Polyotic (tetracycline hydrochloride) with a dosage level of 60 mg/kilogram of body weight was mixed with water and given orally. On 15 January, 1972, the snake was again immobilised and found to have a recurrence of the condition described. The replacement fangs had again lodged within the vagina dentalis and a large amount of exudate had formed. The treatment of the condition was identical to the procedure listed earlier but the antibiotic therapy was extended for five consecutive days.

After repeated attempts to alleviate the condition, it was decided to remove the deficient fang mechanism surgically. Evidently, the continual stress of manually removing the replacement fangs was contributing to the gradual decline of the snake. There was a noticeable loss of body weight. An additional danger was secondary osteomyelitis and the possibility of aspirating the exudate into the respiratory system, or swallowing, resulting in terminal pneumonia or gastroenteritis (see Wallach, 1969). The puff adder was immobilised in the plastic tube and the elongated oval cutouts were sealed. The method of using ether as an anaesthetic (Cooper, 1971) was initiated. When the "righting reflex" was eliminated, the snake was judged to be adequately anaesthetised. It was removed from the tube and gently held behind the head. The level of anaesthesia was continually monitored by periodically giving the snake additional ether with a cotton pad to maintain the soporific state.

The oral cavity was cleaned and the necrotic tissue removed with cotton swabs. A pair of surgical scissors was used to perform the surgery. The maxillary bone was disarticulated from the prefrontal at the maxilla-prefrontal articulation (Fig. 1). At the junction of the ectopterygoid and maxilla, the ectopterygoid is dorsoventrally flattened to insert into a groove on the posterior face of the maxilla. The ectopterygoid was separated from the maxilla at the point of insertion (Fig. 2). The synovial membrane which binds the maxilla and prefrontal and the ligament which attaches to the dorsolateral face of the maxilla were severed. The check ligaments which attach to the posterior spur of the maxilla and are used to prevent hyper-extension of the maxilla were cut. The pterygoideus muscle (nomenclature after Haas, 1952 and Bolt & Ewer, 1964) is divided into two slips—the upper one inserting on the dorsal surface of the ectopterygoid and the lower inserting on the postero-ventral extremity of the maxilla. The lower slip was severed. Since there are tendons from both slips of the pterygoideus which

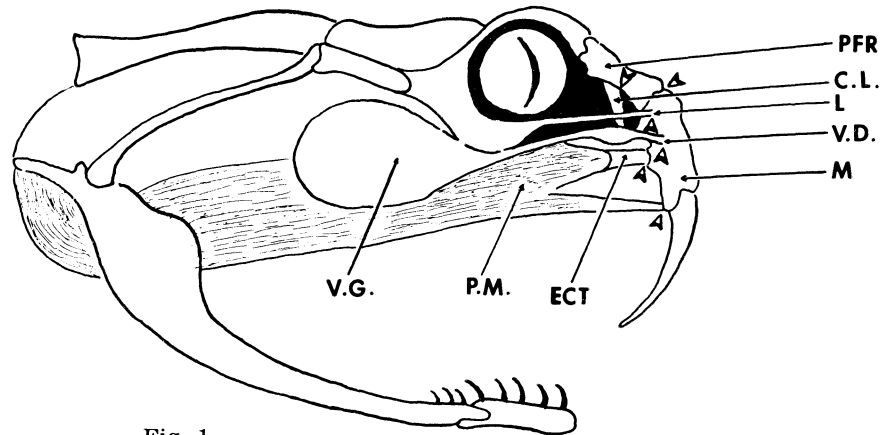

Fig. 1

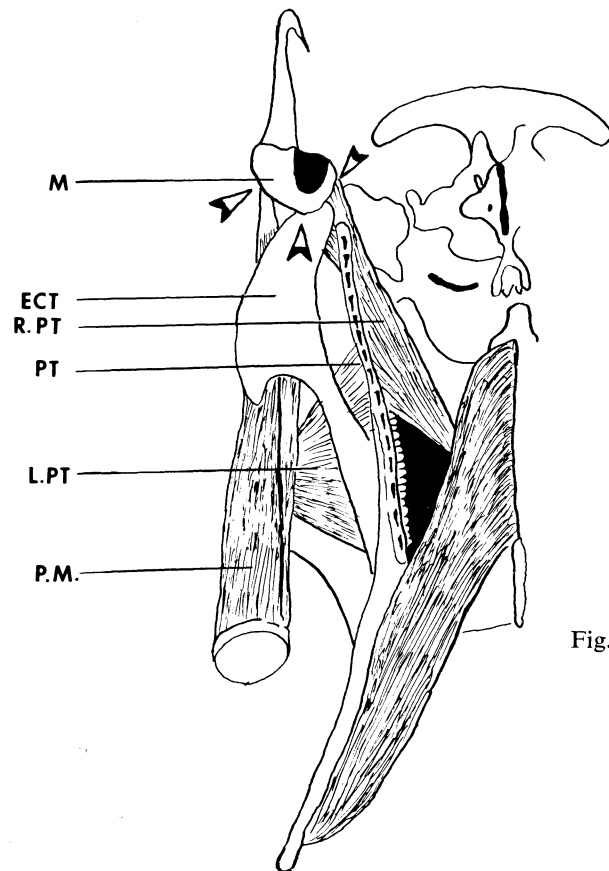

Fig. 2

are attached to the vagina dentalis, they also were removed from the fang sheath. Part of the retractor pyterygoidei inserts on the ventero-mesial face of the maxilla and the muscle was disjoined at this point. The venom duct was cut at the external aspect of the fang. Since there was a considerable amount of hemorrhaging, a liberal amount of chemical hemostat was applied to the major wounds to prevent excessive loss of blood. After the bleeding subsided, Kymar was spread into all necrotic areas and the snake was gently placed into the cage.

Seven days later, the puff adder was immobilised in the plastic tube and the affected areas examined for a reappearance of necrosis. At that time, the oral cavity appeared clear of necrosis and exudate although there was slight serous drainage. After an additional seven days the snake was offered a freshly killed laboratory rat, which was accepted. Rats were taken three times on a weekly basis thereafter.

Forty-two days after the initial surgery, the puff adder was immobilised to check the results of the operation. The maxillary and palatal areas were found to contain some caseous yellowish exudate. The exudate was removed with cotton swabs and the involved portions were irrigated with hydrogen peroxide. The cleansed area was treated with an antibiotic ointment, Forte-Topical (procaine penicillin—neomycin polyomyxin). An antibiotic Bio-Delta (procaine penicillin and dihydrostreptomycin sulfate), dosage 1.0 cc, was injected IM into the lateral musculature with a 1.0 cc tuberculin syringe and 25 gauge needle.

Fifty-nine days after the surgery, the oral cavity of the snake was clear of necrosis and exudate and the wounds had completely healed. No further difficulties from the operation were in evidence.

ACKNOWLEDGMENTS

We thank Dr. Howard K. Gloyd for his critical review of the manuscript.

REFERENCES

BOLT, R. E. and EWER, R. F. (1964). The functional anatomy of the head of the puff adder, *Bitis arietans* (Merr.), *J. Morph.*, **114**, 83-106.  
 COOPER, J. E. (1971). Surgery on a captive gaboon viper. *Br. J. Herpet.* **4** (9), 234-35.  
 HAAS, G. (1952). The head muscles of the genus *Causus* (Ophidia, Solenoglypha) and some remarks on the origin of the Solenoglypha. *Proc. zool. Soc. Lond.*, **122**, 573-92.  
 MURPHY, J. (1971). A method for immobilising venomous snakes. *Inter. Zoo Year book*, **11**, 233, London.  
 WALLACH, J. D. (1969). Medical care of reptiles. *J.A.V.M.A.*, **155**, 1017-34.

PRODUCTS MENTIONED IN TEXT

Bio Delta—Upjohn Corporation, Kalamazoo, Michigan, U.S.A.  
 Forte-Topical—Upjohn Corporation, Kalamazoo, Michigan, U.S.A.  
 Kymar—Armour—Baldwin Laboratories, Omaha, Nebraska, U.S.A.  
 Polyotic—American Cyanamid Company, Princeton, New Jersey, U.S.A.

Fig. 1 Lateral view of head with skin removed to show position of bones and musculature. Arrows indicate location of incisions and disarticulations completed during surgery. PFR, prefrontal bone; C.L., check ligament; L, ligament; V.D., venom duct; M, maxilla; ECT, ectopterygoid; P.M., pterygoideus; V.G., venom gland.

Fig. 2 Ventral view of skull showing position of bones and musculature. Arrows indicate location of incisions and disarticulations completed during surgery. M, maxilla; ECT, ectopterygoid; R. PT, retractor pterygoidei; PT, pterygoid; L. PT, levator pterygoidei; P.M. pterygoideus.

Both Figures modified after Bolt and Ewer (1964).

THE USE OF THE MACROLIDE ANTIBIOTIC TYLOSIN IN  
THE TREATMENT OF REPTILIAN RESPIRATORY INFECTIONS

By

J. B. MURPHY

Dept. of Reptiles, Dallas Zoo, Dallas, Texas, U.S.A.

(Received 4/4/72)

Introduction

Respiratory infections in reptiles, particularly in the advanced stages, are notoriously difficult to treat successfully and these infections have contributed to high mortality in captive reptiles. Generally, the etiology of the disease is unknown (Rothman & Rothman, 1960). A number of different remedies have been proposed for the treatment of respiratory infections with varying degrees of success. The use of Friar's Balsam and an increase of temperature of not less than 75°F for respiratory infections in tortoises has been suggested (Noel-Hume and Noel-Hume in 1954). A combination of oil of eucalyptus and camphorated spirits in conjunction with a blower was used to treat a number of Indian Pythons that were suffering from a respiratory infection (Kauffeld, 1969). O'Connor (1966) recommended the use of daily intra-muscular injections of Chloromycetin (chloramphenicol) or other antibiotics (except streptomycin) with the dosage level determined by using the dog or cat dosage of equivalent body weight. Logan (pers. comm.) suggested using Chloromycetin injected intra-muscularly with a dosage level of 32 mg/kg for six consecutive days. Truit (1962) suggested an injection of 2 cc of Combiotic (penicillin and dihydrostreptomycin) inter-muscularly every 12 hours supplemented with oral dosages of the antihistamine Ornade as long as it is necessary to relieve the mucous congestion. The body weight of the reptile treated was not given. Metzger (1958) used one to three doses daily of 1/2 capsule of Achromycin (tetracycline) and repeated applications of Metimyd, an ophthalmic ointment containing neomycin for the treatment of a female *Testudo horsfieldi*. The temperature was raised to 90°F. Holmes (1954) described the use of sulfanilamide in the treatment of two pythons. Backhaus (1963) suggested using Elkosin (sulfisomidine) and Dextropur for respiratory infections. Penicillin was also recommended. Bustard (1970) felt that the use of Sulfa drugs was warranted for the treatment of pneumonia. A large lizard such as a blue-tongue skink should receive a half tablet and smaller lizards should be given a quarter tablet. Rothman and Rothman (1960) tried a series of medications on a number of snakes with respiratory infections with varying results. Sulfathiazole was used successfully in one case but one *Elaphe scalaris* was given a total oral dose of 625 mg over an eight day period with no success. Penicillin was tried on twelve snakes with dosages ranging from 300,000 units to 1,000,000 injected intra-muscularly every other day without effect. Chloromycetin was injected intra-muscularly with a dosage of 200 mg and then discontinued when no result was observed. Although dihydrostreptomycin sulfate did improve the condition of the snakes treated, nerve damage was in evidence in a South American Boa Constrictor, *Boa c. constrictor*, Black Rat Snake, *Elaphe o. obsoleta* and a hybrid Rat Snake and the use of the antibiotic was discontinued. The authors felt that the greatest success was accomplished with the use of tetracyclines. A 100 mg tablet of Achromycin or Tetracyclin (tetracycline) was placed in the throat although two afflicted snakes did expire. They recommended the use of any of the tetracyclines: Aureomycin (chlortetracycline), Terramycin (oxytetracycline) Achromycin or Tetracyclin (tetracycline) and Declomycin (demethylchlortetracycline). In conjunction with the use of tetracyclines, the authors suggested that the mucus be removed before using the antibiotic.

Since March 1965, the antibiotic tylosin has been used at the Dallas Zoo for the treatment of reptilian respiratory infections and during that time,

the drug has demonstrated remarkable efficacy and a high safety tolerance. The product is produced by Corvel, a division of Eli Lilly and Company. This macrolide antibiotic is produced from the actinomycete, *Streptomyces fradiae*. The antibacterial spectrum includes gram-positive organisms and the action is essentially bacteriostatic. Eli Lilly and Company literature states that the drug is relatively nontoxic. The oral LD<sub>50</sub> is greater than 5 g/kg in mice. Dogs have tolerated oral doses as high as 200 mg and 400 mg/kg for 657 days with only occasional side effects. In swine, the LD<sub>50</sub> by the intra-muscular route is approximately 1,000 mg/kg; by the oral route, greater than 5 grams per kilogram.

Tylocine injection is a sterile solution of tylosin base in 50% propylene glycol with 4% benzyl alcohol. There are 50 milligrams of tylosin activity for every cc.

Tylan plus vitamins is a water soluble powder which contains tylosin and vitamins.

SYMPTOMATOLOGY OF RESPIRATORY INFECTION

Rothman and Rothman (1960) have characterised the development of reptilian respiratory infections into four distinct stages:

- STAGE ONE The reptile begins to wheeze and sneeze. The mouth and throat are filled with a clear, slightly viscous saliva. The reptile is strong but refuses to feed in some cases.
- STAGE TWO The nostrils are closed or bubbling. Feces may be blood-streaked, sticky, foul and sparse. The reptile becomes noticeably weaker. Mucus is whitish, cordlike, thick and in great abundance. Gums may be mottled.
- STAGE THREE Gums may be red, abrade and bleed easily; rales present, lung collapsed but body tissues swollen; snake losing co-ordination, very weak, flaccid, head held high; gapes for long periods; mouth and throat full of purulent, yellow phlegm.
- STAGE FOUR Terminal. Reptile uncoordinated, very weak and thin; little phlegm in throat. The lung is hard and swollen. Death follows quickly.

TREATMENT OF RESPIRATORY INFECTION

The following reptiles in the collection at the Dallas Zoo have been treated with the antibiotic tylosin:

- STAGE ONE Blue-tongue skink, *Tiliqua s. scincoides*.
- STAGE TWO Eyelash Viper, *Bothrops schlegeli*; Indian Russell's Viper, *Vipera r. russelli*; King Cobra, *Ophiophagus hannah*; Red Rattlesnake, *Crotalus r. ruber*; Cantil, *Agkistrodon b. bilineatus*; two Bimini Boa, *Epicrates striatus fosteri*; Gila Monster, *Heloderma s. suspectum*.
- STAGE THREE Green tree Python, *Chondropython viridis*; two South American Boa Constrictor, *Boa c. constrictor*; two Haitian Boa, *Epicrates s. striatus*; Indian Python, *Python m. molurus*; Prairie Rattlesnake, *Crotalus v. viridis*; Star tortoise, *Geochelone elegans*; Eastern Leopard tortoise, *Geochelone pardalis babcocki*.
- STAGE THREE AND FOUR South American Boa Constrictor, *Boa c. constrictor*.

The dosage level used was 25 mg per kg of body weight administered intra-muscularly. For small snakes, the drug was injected with a 1 cc tuberculin syringe with a 25 ga. x 5/8 inch needle. A 10 cc syringe was used for larger serpents. The site of injection was in the lateral musculature approximately 2/3rds the length of the body. For chelonians, the body weight was estimated to be one-third of the total weight of the animal. The injection site was the femoral part of the hind limb for chelonians and saurians. The needle was inserted between the scales.

To avoid undue stress for the reptiles, the water soluble powder Tylan was used whenever possible. The powder was mixed in the food for turtles and lizards or injected in dead rodents for the snakes. In the event that the reptile refused food, the powder was mixed with water and was administered with a syringe and catheter tube.

Venomous snakes were immobilised by being placed in an acrylic plastic tube with one sealed end. The immobilisation tube had elongated cutouts so the catheter could be inserted into the mouth of the reptile (see Murphy, 1971). The catheter tube was lubricated and placed in the esophagus as far as possible posteriorly to the glottis. The minimum temperature level in all cases was 24°C.

#### CASE HISTORIES

Since the antibiotic tylosin was used under a variety of circumstances, a representative sampling of case histories is listed. These cases have been chosen to show the different techniques for administering of the drug, severity of the disease or alteration in the dosage level.

CASE 1 A Common Blue-tongue Skink, *Tiliqua s. scincoides* was suffering from a respiratory infection at Stage One severity. The body weight of the animal was 450 g. Since the lizard was feeding, the dosage level of 11 mg of Tylan was mixed in a banana mash and fed daily for three days. The temperature level was 29°C and the symptoms cleared within three days.

CASE 2 On 15 January, 1972, a Gila Monster, *Heloderma s. suspectum* was suffering from a respiratory infection at Stage Two severity. The lizard gaped frequently and was extremely bloated, particularly in the thoracic region. The amount of mucoid discharge was lower than usual. The body weight of the lizard was 1.2 kg. An egg mixture with Tylan was used with a dosage of 30 mg daily for five days until the condition cleared. The temperature was 29°C.

CASE 3 On 20 December, 1966, an Indian Python, *Python m. molurus* was suffering from a respiratory infection of Stage Three severity. Since it was felt that weighing would cause undue stress, the body weight was estimated to be 25 kg. The snake received daily injections of 625 mg intra-muscularly of Tylocine Injection for a period of seven days until the condition cleared. The temperature was 24°C.

CASE 4 On 19 August, 1969, an Eastern Leopard tortoise, *Geochelone p. baboeki* and an Indian Star tortoise, *Geochelone elegans*, developed respiratory infections of Stage Three severity. Since the Leopard tortoise continued to feed, Tylan was administered in the food. The total body weight of the tortoise was 2.4 kg and the daily dosage of 20 mg was administered for five days. The temperature of the enclosure was maintained at 29°C.

The Star tortoise refused to feed so Tylan was administered with a syringe and catheter. The mouth was gently opened and the mixture was then slowly dripped into the mouth. The body weight of the tortoise was 1.2 kg and the daily dosage was 10 mg for a period of seven days. Recovery for both tortoises was uneventful.

CASE 5 On 15 April, 1966, a Green Tree Python, *Chondropython viridis* was stricken with a respiratory infection of Stage Three severity. The body weight of the snake was 1.0 kg. Tylan was administered daily with a syringe and catheter for a period of seven days. The dosage was 25 mg and recovery was uneventful. The temperature was 24°C.

CASE 6 On 20 July, 1969, a South American Boa Constrictor, *Boa c. constrictor* was donated to the Zoo. This snake had the most extreme symptoms of respiratory infection of any reptile that has ever been treated with tylosin. The snake was judged to have a respiratory infection intermediate between Stage Three and Four. The snake was uncoordinated and weak and thin with little mucus in the throat. The snake gaped constantly and the gums were slightly necrotic. Since the snake was in such poor condition and it was felt that weighing would cause undue stress, the body weight was estimated to be 4.0 kg. Tylan was given daily for a period of seven days. The dosage level was 100 mg and it was administered with a syringe and catheter. The temperature was 24°C. Recovery was uneventful and the snake fed on a freshly killed laboratory rat 14 days after the initial treatment.

CASE 7 On 12 December, 1967, a King Cobra, *Ophiophagus hannah*, was stricken with a respiratory infection of Grade Three severity. The weight of the snake was estimated to be 4.5 kg. since it was felt that weighing would cause undue stress. To test the upper limits of the drug, a daily dosage level of 113.0 mg was given for a period of seven days. Tylan was placed in small pieces of thawed *Pituophis* and offered daily. The temperature was 24°C. Recovery was uneventful.

At the time of writing, 22 March, 1972, all of the reptiles listed in the case histories are still alive and in the reptile collection at the Dallas Zoo, with the exception of the South American Boa Constrictor, *Boa c. constrictor* which was released to another institution shortly after its recovery.

#### DISCUSSION

Generally, the recommendation of the use of an inhalent was rather unsuccessful in the treatment of respiratory diseases in reptiles, particularly in the advanced stages. The use of sulfanilamide was not recommended for the treatment of respiratory difficulties (Rothman & Rothman, 1960) and this conclusion parallels the results found at Dallas Zoo. The same authors found that penicillin had no effects with dosages ranging from 300,000 units to 1,000,000 units injected intra-muscularly every other day. This result also corresponds with the results found at the Zoo. Their greatest success came with the use of Achromycin or Tetracycline (tetracycline) and they felt that probably any of the tetracyclines could be used. Aureomycin (chlortetracycline), Terramycin (oxytetracycline), Achromycin (tetracycline) and DeClomycin (demethylchlortetracycline) have been used at the Zoo with minimal effectiveness. Daily oral dosages of up to 125 mg/kg and intra-muscular injections of 15 mg/kg have been used with poor results. The use of Combiotic (penicillin and dihydrostreptomycin) appears to be of limited value. Somewhat encouraging results were noticed when Chloromycetin was used as suggested by Logan (1967) but tylosin seemed much more effective.

#### SUMMARY

A total of nineteen individual reptiles, comprising 15 species have been treated with the antibiotic tylosin at the Dallas Zoo and the disease has been eliminated in every instance with no mortality. The dosage level recommended is 25 mg per kg body weight injected intra-muscularly with the product Tylocine. The same dosage level is suggested when Tylan is used.

## ACKNOWLEDGEMENT

I would like to thank J. M. Brundrett, D.V.M., for critically reviewing the manuscript.

## REFERENCES

- BACKHAUS, D. (1963). Behringwerk—Mitt. (Marburg) Spec. Suppl., Die Giftschlangen der Erde, pp. 223-253.  
 BUSTARD, H. (1970). *Australian Lizards*, Collins, Sydney, London  
 HOLMES, A. (1954). Some notes on the use of sulphanimide in the treatment of reptile disease. *Br. J. Herpet.* 1 (10), 179-81.  
 KAUFFELD, C. (1969). *Snakes: The Keeper and the Kept*. Doubleday and Co., New York.  
 LOGAN, T. (January, 1967). *Pers. Commun.*  
 LILLY, Eli and Co. (March, 1968). Gen. Lit. on Tylocine Injection.  
 METZGER, D. (1958). Neomycin, Acromycin and their administration in treatment of a respiratory ailment in a tortoise. *Herpetologica* 14. 56.  
 MURPHY, J. (1971). A method for immobilising venomous snakes. *Inter. Zoo Yearbook* 11, 233, London.  
 NOEL-HUME, I. and NOEL-HUME, A. (1954). *Tortoises, terrapins and turtles*, W. and G. Feyle, Ltd., London.  
 O'CONNOR, P. (1966-1967). Diseases of Snakes. In: *Current Veterinary Therapy*. W. B. Saunders Co., Philadelphia and London.  
 ROTHMAN, N. and ROTHMAN, B. (1960). Course and cure of respiratory infection in snakes. *PHS Bull.* 8 (5), 19-23.  
 TRUIT, J. (1962). *The common diseases of captive reptiles*. Coral Gables, Florida. (Published privately).

## PRODUCTS MENTIONED IN TEXT

Achromycin (Lederle). Tetracycline hydrochloride.  
 Aureomycin (Lederle). Chlortetracycline hydrochloride.  
 Chloromycetin (Parke-Davis) Chloramphenicol.  
 Combiotic (Pfizer). Penicillin and dihydrostreptomycin.  
 Declomycin (Lederle). Demethylchlortetracycline  
 Elkosin (Ciba). Sulfisomidine.  
 Metimyd (White). Prednisolone acetate, Sodium sulfacetamide.  
 Ornade (Smith, Kline & French). Chlorpheniramine maleate.  
 Phenylpropanolamine hydrochloride.  
 Isopropanide.  
 Terramycin (Pfizer). Oxytetracycline.  
 Tetracycln (Pfizer). Tetracycline hydrochloride.  
 Tylan, Tylocine (Corvel). Tylosin.

IDENTIFICATION OF NEWT SPECIMENS (URODELA, TRITURUS)  
 BY RECORDING THE BELLY PATTERN AND A DESCRIPTION OF  
 PHOTOGRAPHIC EQUIPMENT FOR SUCH REGISTRATIONS.

By

TORKEL HAGSTRÖM

Department of Zoology, University of Gothenburg, Gothenburg, Sweden.

(Received 13/4/72)

## INTRODUCTION

The question of specimen identification is one of the most fundamental problems in the study of urodelan population dynamics. The toe-clipping method, developed by Twitty (1966) and modified by Efford and Mathias (1969) after Heatwole (1962), does not seem to be useful for Scandinavian newts because of their ability to regenerate toes. In western Sweden, most newts collected have one or more toes under regeneration. Furthermore, no useful methods are known for tattooing or adhering marks to those animals.

## CONSTANCY OF BELLY PATTERN

Edelstam (1954) considered that the distribution of black spots (=dermal layers where the melanophores are numerous and closely packed together) on the bellies of Swedish newts is individual and may be used for specimen identification. The belly pattern, however, is said to depend, for example, on food and genetical factors (Herre, 1933; Freytag, 1951), but is also found to be completed during the third year of life (Smith, 1969). Assuming that the belly pattern remains constant long enough, it would be useful for identifying adult specimens of the species in question: This assumption is supported by a great number of observations by the author on specimens in an aquaterrarium for up to six years.

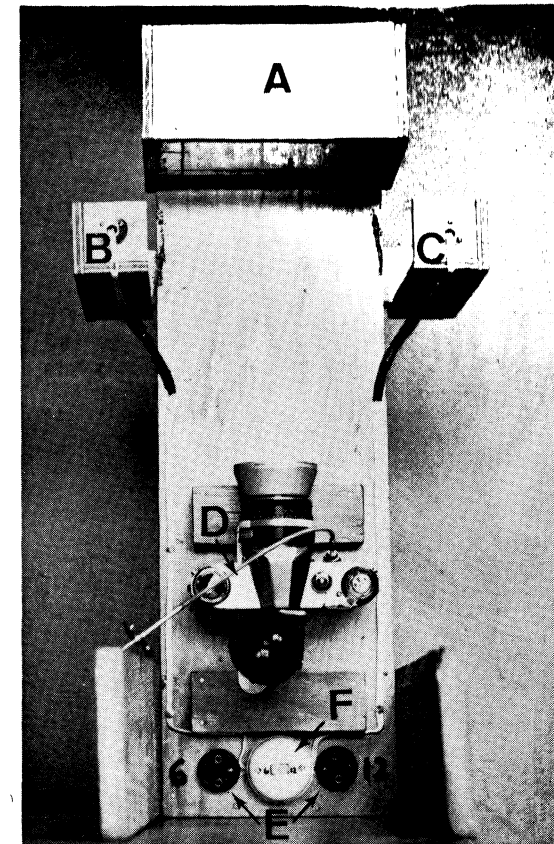

Fig.1

⊗ = 6 V 15 VA lamp

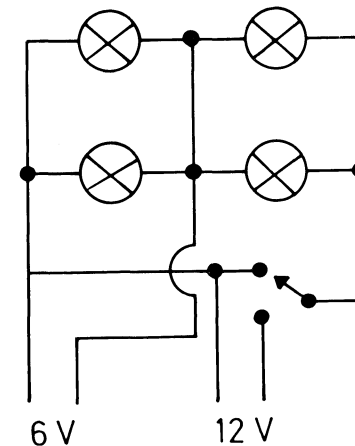

Fig. 2

For three years the belly pattern method has been used for recognizing adult individuals of *Triturus cristatus* (Laurenti) and *T. vulgaris* (L.) in a number of ponds in the Gothenburg area in western Sweden (see Figs. 3-14). Among the animals recaptured, practically no change in pattern was observed, nor have any "border-cases" been collected; without doubt all animals caught on repeated excursions were either recaptured ones or specimens never found before. The degree of recapture can be very high; for example, in a pond in Billdal (15 km S. Gothenburg) where more than 100 *T. vulgaris* are registered, 50% of the specimens collected in 1969 were recaptured in 1970. In the same pond several specimens were caught during 75% of the weekly excursions during the seasons.

#### METHOD AND EQUIPMENT

Each time a sample is taken, all animals caught are photographed one by one from below and then released. Afterwards, photo enlargements are made from all negatives; the pictures can be assorted later in the laboratory. The camera equipment (Fig. 1) used in the field works rather fast; 5 or 6 pictures of newts can be taken in one minute. The camera stand is of wood. On the top is a glass-bottomed box in which the newt is placed in water. Every fifth cm is marked on the edge of the glass to facilitate copying work. A small piece of paper with the date and place is also placed in the box. The camera is fitted under the box facing upwards. Between the camera and glass are two lamps on the left and two on the right side. Finally two boards fixed under the camera permit the equipment to stand vertically.

Electric current for the 4 lamps is obtained from car batteries of 6 or 12 volts. The wiring diagram is shown in Fig. 2.

#### PHOTOTECHNICAL DATA

In theory any type of camera may be used but a single lens reflex camera is the most convenient instrument. A Praktica nova with a Jena T 2.8/50 lens is mounted with a seven mm extension tube, a lenshood and an angle viewer. The distance from the front lens to the subject glass is 31 cm.

Because animals may move during photography a fast shutter speed is essential. In consequence, either a very sensitive film emulsion or lamps of high intensity are necessary. The latter would, however, make the glass too hot. A satisfactory solution is to place four 15 VA lamps 15 cm from the middle of the glass and to use 27-29 DIN film Ilford HP4, which when developed in Ilford Microphen, the correct exposure will be f:4 1/500 sec. This combination of camera lens, film emulsion and developer gives pictures with good contrast and distinct enough for critical examination.

#### DISCUSSION

The method described can be practised in localities where the newt population consists of hundreds, but not thousands of animals. The latter though possible would be an extremely detailed, time-consuming job. There is a practically unlimited variation of belly patterns. In *T. cristatus*, for example, the belly may vary from almost black to almost unspotted (Gislén & Kauri, 1959). Because of this enormous variability, the chance of collecting two newts with exactly the same belly patterns is negligible. However, some specimens mate for the first time when two years old, which means that they have not yet completed their belly pattern and, accordingly, will not look the same the following year. Consequently hardly any of such young newts collected were identified the following year. The two year old animals are, however, not too difficult to distinguish; good descriptions (based on size, colour, pattern, breeding dress and several other characters) are given by Collett (1918). If the belly pattern method is practised during one season only, the young animals will of course be no problem.

Enlarged pictures corresponding to natural size can be compared visually without using any code or scheme.

Fig. 3



Fig. 4

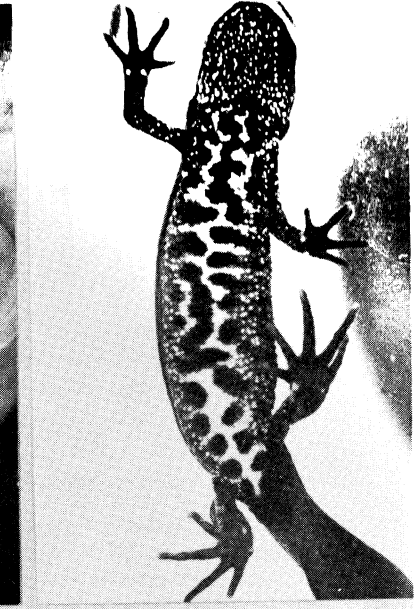

Fig. 5



Fig. 6

Fig. 7

Fig. 8

Fig. 9

Fig. 10

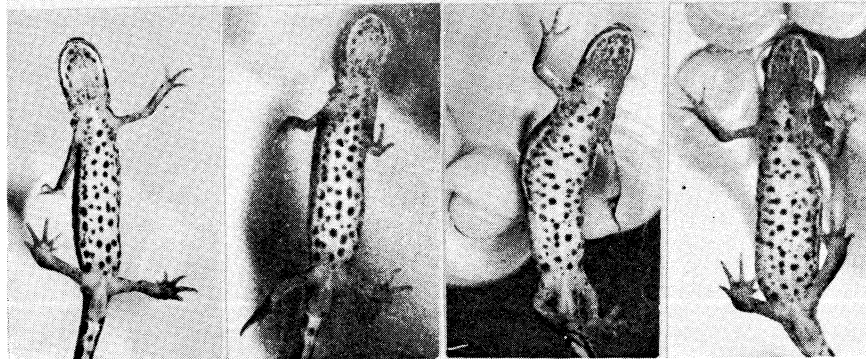

Fig. 11

Fig. 12

Fig. 13

Fig. 14

## SUMMARY

The problem of marking newts is discussed. The method of identifying different specimens by recording their belly patterns, which are regarded as unique to each individual, is considered to be useful for newt populations of moderate size. A number of examples are given from localities in the Gothenburg area in western Sweden, where the method has been practised successfully for *Triturus cristatus* (Laurenti) and *T. vulgaris* (L.) during a period of three years. A description of equipment suitable for photographic registration of belly pattern of newts is given, and technical data are included for instruments and material. Finally, the limitations and the difficulties of the method are discussed.

## REFERENCES

- COLLETT, R. (1918). *Norges krybdyr og padder*. Utgit ved A. Wollbaek. Ashehoug & Co., Kristiania. 104 pp.
- EDELSTAM, C. (1954). Populationsdynamiken hos reptiler och amfibier.—*Statens Naturvetenskapliga Forskningsrads Arsbok* 1952-53: 147-155.
- EFFORD, I. E. and MATHIAS, J. A. (1969). A comparison of two salamander populations in Marion Lake. British Columbia. *Copeia* 1969. 723-36.
- FREYTAG, G. E. (1951). Über das Farbkleid der Salamandriden in seiner Abhängigkeit von äusseren und inneren Faktoren. *Veröff. Zool. Staatssammlung (München)*: 29-124.
- GISLEN, T. and KAURI, H. (1959). Zoogeography of the Swedish amphibians and reptiles. *Acta Vertebratica* 1, 197-397.
- HEATWOLE, H. (1961). Inhibition of digital regeneration in salamanders and its use in marking individuals for field studies. *Ecology* 42, 593-94.
- HERRE, W. (1933). Zur Kenntnis der Zeichnung und Färbung des Teichmolches *Triturus vulgaris* L.—*Zool. Anz.* 104, 177-93.
- SMITH, M. (1969). *The British amphibians and reptiles*. 4th ed. Collins, London. 322 pp.
- TWITTY, V. C. (1966). *Of scientists and salamanders*. Freeman and Co., San Francisco. 180 pp.

- FIGURE 1. Equipment for photographic registration of belly pattern of newts. The whole stand is 65 cm high.  
A. Glass-bottomed subject box.  
B, C. Lampholders  
D. Camera  
E. Electric contacts  
F. Switch 6-12 volts

FIGURE 2. Wiring diagram for lamps to the camera stand in FIGURE 1.

FIGURE 3. *Triturus cristatus*, male, photographed in 1969.

FIGURE 4. The same animal of FIGURE 3, recaptured in 1971.

FIGURE 5. *T. cristatus*, male, photographed in 1969.

FIGURE 6. The same animal of FIGURE 5, recaptured in 1971.

FIGURE 7. *T. vulgaris*, male, photographed in 1969.

FIGURE 8. The same animal of FIGURE 7, recaptured in 1971.

FIGURE 9. *T. vulgaris*, male, photographed in 1969.

FIGURE 10. The same animal of FIGURE 9, recaptured in 1971.

FIGURE 11. *T. vulgaris*, female, photographed in 1969.

FIGURE 12. The same animal of FIGURE 11, recaptured in 1971.

FIGURE 13. *T. vulgaris*, female, photographed in 1969.

FIGURE 14. The same animal of FIGURE 13, recaptured in 1971.

The newts were collected in the Gothenburg area in western Sweden. Natural size.

## COMMENTS ON THE AGE OF THE FROG FAMILY PIPIDAE

By

COLEMAN J. GOIN and OLIVE B. GOIN

Museum of Northern Arizona, Flagstaff, Arizona 86001, U.S.A.

(Received 20/4/72)

Since the fossil record of frog families is far from complete, anything that sheds light on the early evolution of frogs is worthy of note.

We have recently (Goin and Goin, in press) advanced the hypothesis that the frogs originated in Antarctica and spread northward from that region. Griffiths (1963) considers the *Ascaphidæ* (including *Leiopelmidæ*), *Pipidæ*, and *Discoglossidæ* to be primitive families, the *Pelobatidæ* to be a family that couples the primitive and the advanced families, and the *Ranidæ*, *Hylidæ*, *et al.* as comprising an advanced group of families. Following this classification, we attempted to trace the zoogeographic history of these groups.

The evidence suggests that the advanced families spread outward from Antarctica after Gondwana began breaking apart since not all families reached all of the present continents (or have reached them only recently). The hylids and leptodactylids are distributed primarily in Australia and South America. The ranids are centered in Africa, the bufonids and microhylids in Africa, South America, and southern Asia.

On the other hand, the present distribution of the pipids suggests that they once had a continuous distribution in what is now central South America and central Africa. The forms on the two continents are even today so closely related that Dunn (1948) in his review of the group concluded that "the American species form a natural group as opposed to the African species, but the differences cannot be considered as of more than generic value."

It is now generally accepted that the continents once formed a single land mass, *Pangaea*. This broke apart into Laurasia, comprising the present Eurasia (except India) and North America, and Gondwana, comprising the southern continents and India. The Antarctic-Australian land mass separated from the African-South American land mass and India broke away to move northward and abut Asia. North and South America on the west moved away from Europe and Africa on the east to give rise to the Atlantic Oceans. It is rather firmly established that the cleavage between South America and Africa first developed in the south and progressed northward.

If the range of the pipids was once continuous across Africa and South America, they must have reached that region before the separation of these two continents. There is no evidence, however, that the pipids ever reached India or Australia. They probably were not present in Gondwana then before the separation of India and the Antarctica-Australia land mass from the Africa-South America mass.

While there is some difference of opinion on the timing of these events, Dietz and Holden (1970) believe the evidence indicates that Antarctica-Australia and India had moved away from Africa-South America by the end of the Triassic, 180 million years ago, and that by the end of the Jurassic, 135 million years ago, the split between Africa and South America had moved as far north as present day Nigeria. This evidence seems to us to indicate that the *Pipidae* were not yet present at the end of the Triassic but were firmly established as a family by the end of the Jurassic. This timing fits in well with Nevo's (1968) description of *Thoraciliacus* and *Cordicephalus* from the Lower Cretaceous of Israel as the oldest known definitive pipoids.

*Eobatrachus* from the Jurassic of Wyoming has been considered by some (Hecht and Estes, 1960) to be a possible pipoid but Nevo (1968) questions this and we are inclined to concur with him on zoogeographic grounds. Moodie (1912) suggested that it was a bufonid and Reig (1958) referred it to the *Discoglossidae*. We suggest that it be restudied to see if it might more appropriately be referred to the *Ascaphidae*.

If *Eobatrachus* and *Eodiscoglossus* from the Upper Jurassic of Europe should ultimately be shown to be *ascaphids*, this would indicate that the *Ascaphidae* slightly predated the *Pipidae*. The more advanced families did not appear until after the separation of the continents was accomplished, that is, after the close of the Jurassic.

## REFERENCES

- DIETZ, R. S. and HOLDEN J. C. (1970). The break-up of Pangaea. *Sci. Amer.* 223 (4), 30-41.  
 DUNN, E. R. (1948). American frogs of the family Pipidae. *Amer. Mus. Nov.* No. 1384:1-13.  
 GOIN, C. J. and GOIN, O. B. (1972). Antarctica, isostasy, and the origin of frogs. *Quart. Jour. Fla. Acad. Sci.* (In press).  
 GRIFFITHS, I. (1963). The phylogeny of the Salientia. *Biol. Rev.* 38, 241-92.  
 HECHT, M. K. and ESTES, R. (1960). Fossil amphibians from Quarry Nine. *Postilla*, No. 46, 1-19.  
 MOODIE, R. L. (1912). An American Jurassic frog. *Am. J. Sci.* 34, 286-88.  
 NEVO, E. (1968). Pipid frogs from the Early Cretaceous of Israel and pipid evolution. *Bull. Mus. Comp. Zool.* 136 (8), 255-318.  
 REIG, O. A. (1958). Proposiciones para una nueva macrosistemática de los anuros. *Physis*, 21, 109-18.

RHYTHMIC ACTIVITY IN GROUND DWELLING AGAMID LIZARD,  
*SITANA PONTICERIANA* CUVIER

By

M. V. SUBBA RAO\* and B. S. RAJABAI,  
Department of Zoology, Sri Venkateswara University,  
Tirupati, A.P., India.

(Received 31/1/72)

\*Present address: Post Graduate Department of Zoology, Utkal University, Cuttack-3, Orissa, India.

## Introduction

Studies on the locomotor activity rhythm, one of the indicators often chosen for investigating the diurnal rhythms in different organisms, have contributed considerably to our understanding of the problems in this field. (See Cloudsley-Thompson, 1961a, b, 1963b, 1965; Evans, 1966; Bustard, 1967, 1968; Subba Rao, 1970).

Investigations carried out under controlled conditions of light proved the persistence of rhythms in continuous darkness as well as in continuous illumination, at least for a few cycles. Light inhibited activity in the gecko, *Tarentola annularis* (Cloudsley-Thompson, 1965).

The susceptibility of the rhythms to phase shifts (see Harker, 1953, 1961; Webb and Brown, 1959) and the reversal of the locomotor activity rhythms under reversed conditions of light in *Lacerta agilis* and *L. muralis* (Kayser and Marx, 1951) have been well documented.

The object of this study is to consider the significance of light in the activity cycle of the tropical agamid *Sitana ponticeriana* Cuvier.

## MATERIALS AND METHODS

The apparatus used for recording the locomotor activity was similar to that used by Naylor (1958).

The locomotor activity of the lizards recorded automatically on smoked paper, was registered continuously for two full days at one speed and for eight days at another in *S. ponticeriana*. The data are based on 80 completed 24 hour recordings involving 8 specimens of *S. ponticeriana* (4 males and 4 females) for each experiment during 1965 and 1966 (Room temperature: 30° ± 0.1°C range).

The transparent boxes were suspended about their median transverse axis so that when animals moved or walked along the length of the chamber, the latter tilted to one side and an attached lever made a nearly vertical line or mark on smoked paper. The constant rate of movement of the paper was known and thus the hourly activity ascertained. The number of flicks per hour was considered proportional to the animal's locomotor activity. By carefully adjusting the lever sensitivity and the position of the boxes it was possible to record simultaneously the activity of 4 animals each in a separate screened-off container on a single smoked paper. The chambers were opaque and large enough for the lizards (Mean weight: 1.260 gm) to move freely.

The activity of the animals during each hour was determined by counting the number of vertical marks recorded. Hourly activity was plotted in block histograms denoting the patterns of activity. In all cases animals were not fed during the course of the experiments.

LOCOMOTOR ACTIVITY IN NORMAL DAY AND NIGHT CONDITIONS AT ROOM TEMPERATURE AND HUMIDITY: The recording equipment was set up in a spacious, well-ventilated room. One of its sides was completely filled with transparent glass shutters and ventilators that were constantly open. The room was thus exposed to cyclical variations of light, temperature and humidity by being in almost direct communication with the outside atmosphere under natural (normal) day and night conditions. The activity of the lizards (size and sex noted) was recorded (*vide supra*).

**CONTROLLED CONDITIONS OF LIGHT AND DARKNESS OF 12:12 HOURS AT ROOM TEMPERATURE AND HUMIDITY:** These experiments were conducted to see whether the pattern of rhythm differs from that seen under natural day-night conditions. During day time (06.00-18.00h) natural daylight was replaced by artificial light from two 60 Watt electric bulbs situated approximately 2 metres distance; at night (18.00-06.00h) they were turned off. Thus the 24 hour cycle of artificial light and darkness corresponded approximately to the natural day and night. Temperature and relative humidity were not controlled.

**REVERSAL OF RHYTHM BY REVERSED LIGHTING IN NORMAL ROOM TEMPERATURE AND HUMIDITY:** Light:Dark cycles of 24 hours duration (L:D, 12:12) were reversed; the day-time was dark and the night-time was illuminated by using the above source of light. The light regime of 12 hours, from 18.00-06.00h alternated with dark period of 12 hours duration from 06.00-18.00h.

**LOCOMOTOR ACTIVITY IN CONTINUOUS DARKNESS AND CONTINUOUS ILLUMINATION AT ROOM TEMPERATURE AND HUMIDITY:** The lizards were placed in opaque animal chambers for recording the activity in continuous darkness in the dark room. For continuous illumination, the above source of light was utilised for recording the activity of the lizards.

Fig.1

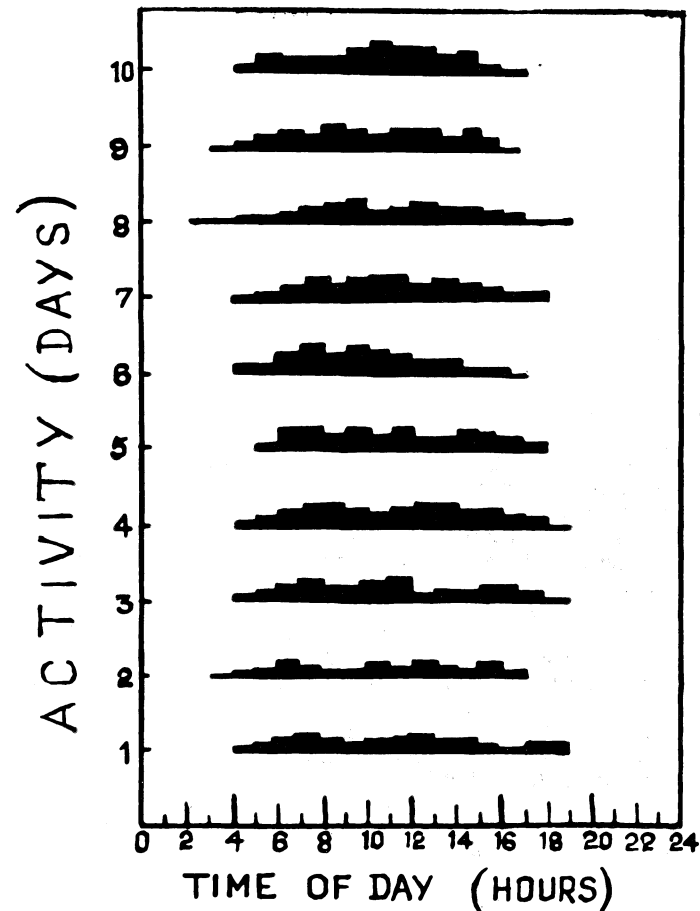

## RESULTS

**PATTERN OF LOCOMOTOR ACTIVITY RHYTHM IN NORMAL DAY AND NIGHT CONDITIONS AT ROOM TEMPERATURE AND HUMIDITY (Fig. 1):** *Sitana ponticeriana* exhibited a clear cut rhythm of locomotor activity under natural conditions of day and night. The active locomotory phase commences on most days between 04.00 and 05.00h. From then onwards the activity was truly diurnal, almost continuous though not uniform throughout the active period. Peak activity on most days appeared between 07.00 and 08.00h and in some cases lasted for few hours. This single active period alternates with an inactive period and hence *S. ponticeriana* is truly monophasic, that is without many short active periods alternating with inactive periods during 24 hours. A few movements were perceived during the inactive or quiescent period.

**LOCOMOTOR ACTIVITY UNDER CONTROLLED CONDITIONS OF LIGHT: DARKNESS (12:12) (NORMAL) AT ROOM TEMPERATURE AND HUMIDITY:** When the lizard was subjected to light:dark cycles of 12:12 hours, at room temperature, the activity rhythm was similar to that under natural conditions (Fig. 1) and persistent. The activity appeared immediately after the onset of light showing that light initiates the activity. Here also the active phase started at about 18.00h. As long as the 24 hour cycle of light and darkness (12:12) continues, there was a clear-cut 24 hour rhythm with the onset of active phase synchronising with the onset of light.

That the onset and cessation of activity follows the appearance and disappearance of light respectively suggests that light is a master synchroniser or phase setting factor in the absence of their daily variations.

**STUDIES OF THE LOCOMOTOR RHYTHM IN REVERSED LIGHTING AT ROOM TEMPERATURE AND HUMIDITY:** When the lizards were subjected to reversed conditions of light and darkness, the reversal of the locomotor rhythm was demonstrated. This reversal was quick and sudden, in synchrony with the reversed light conditions which thus means that the activity is not endogenous and environmental factors such as light principally may initiate the rhythm.

**LOCOMOTOR ACTIVITY UNDER CONSTANT DARK AND CONSTANT LIGHT CONDITIONS WITH ALL THE OTHER NATURAL PERIODIC VARIABLES UNCONTROLLED AT ROOM TEMPERATURE AND HUMIDITY:** The pattern of activity became arrhythmic in the majority of cases. Similar trends were observed when the animals were maintained under constant light conditions.

The phasing of onset of activity with reference to the time of day was strikingly different, in many cases, from that in natural conditions, thereby suggesting that diurnal variations in light may be an important phasing factor.

## DISCUSSION

The results suggest that the locomotor activity rhythm under natural day-night conditions is persistent and the onset of activity is synchronised with the onset of light (and perhaps other factors) associated with changes following cessation of dark period. With only one period of activity in a day, spread over a period of 10 to 12 hours and starting from about 05.00h, the experimental lizards are strictly monophasic like the cockroach (Gunn, 1940) and scorpion (Gopalakrishna Reddy, 1966). Furthermore the locomotor activity of *S. ponticeriana* synchronises with its diurnal and respiratory activities (Subba Rao, 1970).

Roberts (1960) and Gopalakrishna Reddy (1966) subjected cockroaches and scorpions respectively to an artificial light-dark regime (12:12 hours) and showed that the active phase always begins at or shortly after the light to dark transition. Similar results were obtained with *S. ponticeriana* subjected to light:dark cycles of 12:12 corresponding to the natural changes (daylight was replaced by artificial light). Since these lizards are strictly diurnal the activity phase occurs after the onset of light (at about 06.00h, i.e. the transition period from dark to light). This suggests that under light:dark 12:12 constant conditions "light-off stimulus" or the onset of darkness acts as a "clue" or "zeitgeber" for setting the phase of the rhythm.

Reversal of rhythms (under reversed conditions of light and darkness) has been demonstrated in lizards (Park, 1938; Kayser and Marx, 1951), but it was not possible to induce two activity peaks in 24 hours by illuminating them for 4 hours in the morning and 4 hours at night. In the case of the scorpions, *Scorpio* (Harker, 1958) and *Heterometrus fulvipes* (Gopalakrishna Reddy, 1966) the reversed rhythms return to the normal phase under constant light conditions. Similar reversal of rhythm occurs in the lizard, *S. ponticeriana*. The reversal of the rhythm in accordance with the reversed light-dark conditions was quick and without any transients so characteristic of entrained endogenous oscillators (Pittendrigh and Bruce, 1957, 1959). Even under reversed conditions, the activity phase strictly coincided with the 12 hour artificial light period and vice-versa. This demonstrates the well-documented phase susceptibility of biological rhythms.

Thus the locomotory activity of these lizards is controlled by the environmental change from light to dark (or vice versa) and hence the rhythm is exogenous (Brown, 1959).

## SUMMARY

A clear cut locomotor activity rhythm has been described in the agamid lizard, *Sitana ponticeriana* Cuvier. The active phase commences between 04.00 and 05.00h and lasts for about 12 hours. The rhythm is truly monophasic with only a single period of activity in a cycle of 24 hours. Light is the master synchroniser or phase setting factor in the absence of other conspicuous daily variations.

## ACKNOWLEDGEMENTS

We wish to thank Prof. K. Pampapathi Rao, Professor and Head of the Zoology Department, Bangalore University, for the encouragement and discussions. M. V. S. Rao also wishes to thank the University Grants Commission, New-Delhi for the award of a Research Scholarship during the tenure of which this investigation was carried out.

## FIGURE 1.

Analysis of aktograph records showing the pattern of locomotor activity rhythm in normal day and night conditions at room temperature, in *Sitana ponticeriana* Cuvier.

The zero hour, starting at the left of the horizontal scale, represents midnight.

## REFERENCES

- BROWN, F. A. Jr. (1959). Living clocks. *Science* **130**, 3388.  
 BUSTARD, H. R. (1967). Activity cycle and thermoregulation in the Australian gecko, *Gehyra variegata*. *Copeia* **753-58**.  
 BUSTARD, H. R. (1968). Temperature dependent activity in the Australian gecko, *Diplodactylus vittatus*. *Copeia* **606-11**.  
 CLOUDSLEY-THOMPSON, J. L. (1961a). Some aspects of the physiology and behaviour of *Galeodes arabs*. *Ent. Exp. and Appl.* **4**, 257-63.  
 CLOUDSLEY-THOMPSON, J. L. (1961b). *Rhythmic activity in animal physiology and Behaviour*. (Vol. 1 of Theoretical and Experimental Biology). Academic Press, New York and London.  
 CLOUDSLEY-THOMPSON, J. L. (1963b). Light responses and diurnal rhythms in desert Tenebrionidae. *Ent. Exp. and Appl.* **6**, 75-8.  
 CLOUDSLEY-THOMPSON, J. L. (1965). Rhythmic activity, temperature tolerance, water relations and mechanism of heat death in a tropical skink and gecko. *J. Zool.* **146**, 55-69.  
 EVANS, K. J. (1966). Responses of the locomotor activity rhythms of lizards to simultaneous light and temperature cycles. *Comp. Biochem. Physiol.* **19**, 91-103.  
 GOPALAKRISHNA REDDY, T. (1966). Studies on the behaviour of a selected arachnid with special reference to diurnal activity rhythms. *Doctoral dissertation, Sri Venkateswara University*.  
 GUNN, D. L. (1940). The daily rhythm of activity of the cockroach, *Blatta orientalis*. I. Aktograph experiments, especially in relation to light. *J. exp. Biol.* **17**, 267-77.  
 HARKER, J. E. (1958). Diurnal rhythms in the animal kingdom. *Biol. Rev.* **33**, 1-52.  
 HARKER, J. E. (1961). Diurnal rhythms. *Ann. Rev. Ent.* **6**, 131-46.  
 KAYSER, C. H. and MARX, C. H. (1951). Le rythme nycthermal de l'activité et la mémoire du temps chez le lézard (*Lacerta agilis* et *Lacerta muralis*). *XX Congr. Int. Philos. Sci., Paris*. **6**, 96-103.

- NAYLOR, E. (1958). Tidal and diurnal rhythms of locomotor activity in *Carcinus maenas*. *J. exp. Biol.* **35**, 602-10.  
 PARK, O. (1938). Studies in nocturnal ecology. VII. Preliminary observations on Panama rain forest animals. *Ecology* **19**, 208-23.  
 PITTENDRIGH, C. S. and BRUCE, V. G. (1957). An oscillator model for biological clocks. In: *Rhythmic and synthetic processes in growth*. (D. Nudnick, Ed.) pp.75-109, Princeton University Press, Princeton, N.J.  
 PITTENDRIGH, C. S. and BRUCE, V. G. (1959). Daily rhythms as coupled oscillator systems and their relation to thermoperiodism and photoperiodism. In: *Photoperiodism and related phenomena in plants and animals*. (R. B. Withrow, Ed.), pp. 475-505, A.A.A.S., Washington, D.C.  
 ROBERTS, S. K. de F. (1960). Circadian activity rhythms in cockroaches. I. The free running rhythm in steady state. *J. Cell. Comp. Physiol.* **55**, 99-110.  
 SUBBA RAO, M. V. (1970). Studies on the biology of two selected lizards of Tirupati. *Br. J. Herpet.* **4**, 151-54.  
 WEBB, H. M. and BROWN, F. A. Jr. (1959). Timing long cycle physiological rhythms. *Physiol. Rev.* **39**, 127-61.

## TWO OBSERVATIONS ON LEARNING IN ANURANS

By

S. J. GORZULA

University Marine Biological Station, Millport,  
Isle of Cumbrae, Scotland.

(Received 17/5/72)

(i) ARBOREAL BEHAVIOUR IN *Rana temporaria*.

Two young *Rana temporaria* (about eight months old) were kept for two months in a vivarium with eight adult *Hyla arborea* during the early spring of 1965. All frogs were then transferred to a small glass aquarium containing a few twigs. In the aquarium *Rana temporaria* "roosted" in the top corners, adhering to the glass using their stomachs, thighs, and forearms, in a similar fashion to *Hyla*. If the *Rana temporaria* were placed in the branches of a small tree it was observed that they would jump readily between twigs up to 18 inches apart. Their posture in the tree was similar to *Hyla*. Young specimens of *Rana temporaria* which had had no previous contact with *Hyla* were unable to maintain themselves in the tree.

## (ii) DIET MODIFICATION (AUTUMN 1966).

Adult specimens of *Rana temporaria*, *Bufo bufo*, *Bufo woodhousei*, *Bufo calamita*, and *Bufo regularis* were all taught to accept unnatural food materials (pieces of steak, bacon, and vermicelli) from the end of a stick, after a series of preconditioning trials using meat disguised in a cast locust skin. A young *Rana temporaria* of this group, which had itself not undergone training, was then also observed taking food in this manner. This individual was placed in an aquarium with seven naive three month old *Rana ridibunda*. Food was then presented to all eight frogs on subsequent days. On the first day, only the *Rana temporaria* would accept food from a stick, although all frogs fed readily on flies during the following two weeks. On the fourteenth day of their association meat was again presented to all frogs and six *Rana ridibunda* accepted. A control experiment using six naive *Rana ridibunda* only, showed no acceptance of meat after one, seven, eight, and seventeen days. Maggots were readily eaten on the eighteenth day.

The experimental batch of *Rana ridibunda* were then removed and placed in a vivarium with about thirty *Kassina senegalensis*, *Hyperolius marmoratus*, and *Phrynobatrachus* spp.. After an association of ten days the *Kassina* and *Phrynobatrachus* would also accept food from the end of a stick.

## DISCUSSION

The behaviour of certain young anurans is thus shown to be considerably adaptable to their immediate situation. Thus a ground-dwelling species (*Rana temporaria*) can learn the perching and jumping coordination necessary for arboreal existence, if kept with tree-frogs (*Hyla arborea*). Neill and Grubb (1971) have shown that *Bufo valliceps* will adopt arboreal habits, due to intra-specific competition for food and suitable retreats. Modification of food acceptability likewise can be brought about rapidly. *Rana ridibunda* learnt to take food from a stick after observing *Rana temporaria* being so fed only once. Such rapid inter-species learning appears not to have been described previously in "lower" vertebrates. The survival value of such behavioural plasticity is obscure. In part it may enable maximum exploitation of available food material. But, the mechanism maintaining ecological niches in the face of such potential adaptability then becomes an intriguing question. Possibly the adoption of a "correct" species behaviour is preferentially reinforced in the company of sufficient adults of the same species. An analogous situation obtains during learning of bird-song.

## ACKNOWLEDGEMENT

I would like to thank Dr. P. G. Moore for reading this manuscript.

## REFERENCE

NEILL, W. E. and GRUBB, J. C. (1971). Arboreal habits of *Bufo valliceps* in central Texas. *Copeia* No. 2, 347-8.

DEFENSIVE BEHAVIOUR OF A CAPTIVE COLUBRID,  
*RHINOCHAILUS LECONTEI*

By

S. J. GORZULA

The University Marine Biological Station, Millport,  
Isle of Cumbrae, Scotland.

(Received 23/4/72)

In September 1970 I obtained a juvenile specimen of *Rhinocheilus lecontei*, caught in the Mojave desert a few weeks previously. The specimen was 25 cm long (adults grow up to 90 cm). *R. lecontei* has a distinct colouration consisting of thirty-six black dorso-lateral bands. In between each of these is a pink lateral band, above a secondary black bar. The ventral surface and the intermediate dorsal bands are cream colour. Other non-venomous species with similarly distinctive markings apparently mimic the venomous coral snakes of the genus *Micrurus*.

In captivity *R. lecontei* readily burrowed into sand. If prevented it adopted a threat posture (Fig. 1a). Here eight pairs of primary black bands reinforce each other making the snake highly conspicuous. During this display it hissed and struck. If stimulation was continued a second posture was adopted (Fig. 1b). The body assumed a rigid knotted form, showing similar amounts of dorsal, lateral, and ventral surface from all angles. The head was normally at the centre of the knot. Thus the outline of the snake was effectively broken up, especially on gravel. It remained in this posture for several minutes and then attempted to burrow.

Therefore, both warning and cryptic colouration are exhibited by *R. lecontei* at different levels of stimulation.

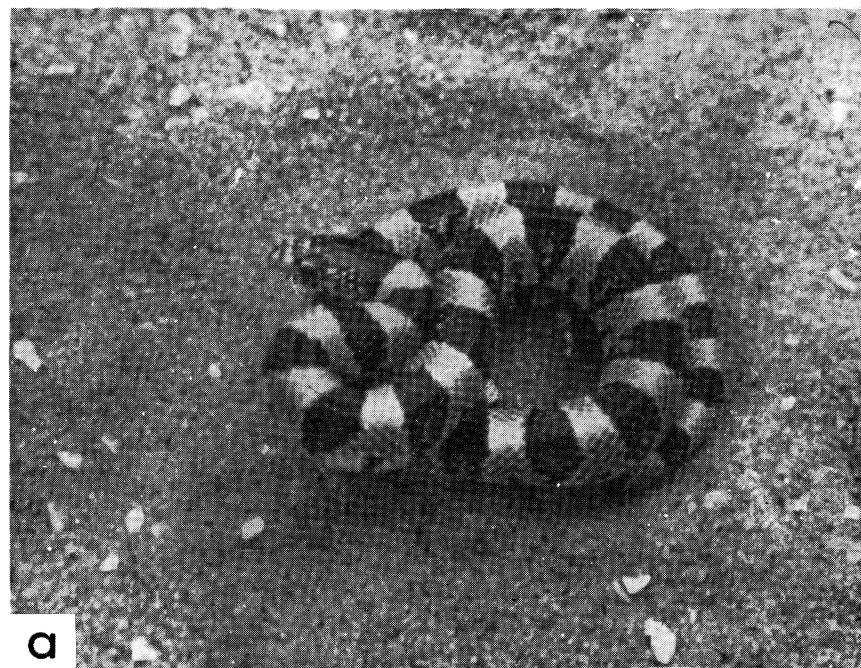

a



b

## ACKNOWLEDGEMENT

I would like to thank Robert S. Ashe for giving me the specimen of *Rhinocheilus*.

NOTES ON THE REPRODUCTION OF THE SOUTHERN  
SMOOTH SNAKE (*CORONELLA GIRONDICA*)

By

D. J. STREET

5 Devonshire Road, London S.W.19.

(Received 11/9/72)

It is well-established that the smooth snake (*Coronella austriaca*) is an ovo-viviparous species, producing from 2-15 fully-developed young, usually in August or September. There has, however, been considerable confusion regarding its close relative, the southern smooth snake (*Coronella girondica*), and the method by which it produces its offspring. Consultation of various authors on this subject provides a rather contradictory picture and detailed data are conspicuously absent.

Boulenger (1913) referred to a female specimen found dead on a road near Bordeaux at the end of June, which was reported to have contained eggs. These however did not contain obviously visible embryos. Boulenger concluded that the young would not have been born until at least two months later, thus leaving the question concerning its method of reproduction unsolved.

Ditmars (1931) commenting on the difference between members of the American genus *Lampropeltis* and those of *Coronella* maintained that the latter are distinguished by being viviparous. Later Angel (1946) reported that the issue regarding the southern smooth snake's oviparity or ovo-viviparity had still not been settled. More recently, however, Hellmich (1962) recommends that any young born in captivity should be removed at once, presumably on account of the mother's supposed cannibalistic tendencies. Steward (1971) simply states that the young are born in August or September. These statements surely imply that this species is ovo-viviparous. Hvass (1972) remarks that the breeding habits of *Coronella girondica* are the same as those of *Coronella austriaca*. While maintaining that this species is oviparous Bruno (1966) adds that its reproduction is similar to that of its close ally. He states further that it is not cannibalistic, and that the young remain with their mother for some days after birth.

In May 1972 the author visited Spain, hoping to find specimens of *Coronella girondica*. On a cold morning of 14th May a quarry near Burgos in Northern Spain was searched. The sky was heavily clouded and there were frequent outbreaks of drizzle. As it had been raining during the previous night, the ground was very wet. Conditions were thus wholly unsuitable for reptiles, more especially for this species which is noted for its preference for dry, even arid situations. Nevertheless two specimens were found hiding under stones which were situated only a few metres apart. The soil beneath them was very damp and both snakes were uncharacteristically cold and clammy. A slug had even attached itself to one of them.

On both specimens the dorsal scales were arranged in the normal 21 longitudinal rows. The larger specimen (female) about 49 cm long, possessed 184 ventral shields, a divided anal shield and 53 subcaudals. The smaller (male) had 180 ventrals, a divided anal and 64 subcaudals. Their colouration was almost identical. This confirmed an impression gained from examination of previous specimens, that there is no conspicuous sexual dimorphism, such as exists with *Coronella austriaca* (Street, 1967).

The two snakes were kept together in a vivarium and though they were watched daily no mating was observed. By the middle of June, however, it was evident that the female was pregnant.



Fig. 1

At 11.15 on the morning of July 23, an egg was discovered amid the female's coils. A second was laid between 14.00 and 15.00, a third at 20.00 and a fourth about two hours later. The fifth and sixth eggs were laid between midnight and 7.00 the following morning. The seventh and final egg emerged at 15.04 later that day. The time that elapsed between the first visible appearance of an egg and the completion of laying varied from 1½ to 3 minutes (Figs. 1, 2).

The elongate eggs were opaque, uniformly ivory in colour and had minute, barely visible longitudinal striations. Their lengths and diameters were:

23 x 13.5 mm.	23.5 x 14 mm.
20 x 14 mm.	25 x 13 mm.
23 x 14 mm.	23 x 15 mm.
24 x 14 mm.	

The shells were tough and leathery, characteristic of oviparous species. These eggs did not adhere together, unlike those of some other species of snakes.

After 24 hours some of the eggs showed signs of shrivelling. Then all seven were kept half submerged in moist sawdust, covered with damp moss at about 22° C. Within a week all signs of shrivelling had disappeared and the eggs looked very healthy. By the end of three weeks they had all grown a little. However, near the end of the fourth week they started to shrivel one by one, and did not respond to increased humid conditions. Soon afterwards they started to discolour and it was obvious they had perished.



Fig. 2

It seems likely that statements claiming this species to be ovo-viviparous have been made on the assumption that a species so closely related to *Coronella austriaca* would be likely to have a similar method of reproduction.

The author has not heard of any authenticated instances of cannibalism, though it is possible that this may occasionally occur. During the summer months of 1965 an adult male was kept together with two young specimens, both of which were less than a year old. They all fed upon common lizards (*Lacerta vivipara*) and the adult showed no interest in the young snakes.

#### ACKNOWLEDGEMENT

The author is greatly indebted to Mr. Eric Hosking and his son David for their vigilance and infinite patience in order to obtain a photographic record.

#### REFERENCES

- ANGEL, F. (1946). Faune de France, 45 Reptiles et Amphibiens. Lechevalier, Paris.  
 BOULENGER, G. A. (1913). *The snakes of Europe*. Methuen, London.  
 BRUNO, S. (1966). Sulle specie del genere *Coronella* Laurenti viventi in Italia. (Terzo contributo alla conoscenza degli Ofidi italiani). *Atti Acc. Gioenia Sc. Nat. Catania* (6) 18, 99-117.  
 DITMARS, R. (1931). *Snakes of the world*. Macmillan, New York.  
 HELLMICH, W. (1962). (English trans. Leutscher, A.) *Reptiles and Amphibians of Europe*. Blandford Press, London.  
 HVASS, H. (1972, English trans. Vevers, G.). *Reptiles and Amphibians in Colour*. Blandford Press, London.  
 STEWARD, J. W. (1971). *The snakes of Europe*. David and Charles, Newton Abbot.  
 STREET, D. J. (1967). The Smooth Snake (Animal of the month) *Animals*, Vol. IX/12, Nigel Sitwell, Ltd., London.

FIGURE 1. Southern smooth snake (*Coronella girondica*) showing egg emerging from cloaca.

FIGURE 2. Southern smooth snake (*Coronella girondica*), female and eggs.

## CLAY "NESTS" OF TOAD TADPOLES

By

DR. EVZEN OPATRNY

Department of Zoology, Palacky University,  
Olomouc, Czechoslovakia.

(Received 24/5/72)

In the warm lowlands of central Moravia of Czechoslovakia the green toad *Bufo viridis*, Laurenti 1768, is one of the most common amphibians. Last year, 1971 a large number of tadpoles were discovered in some shallow puddles each about 0.5 to 3 m in diameter at the margin of a wheat field near Olomouc (cca 49° 35' N, 17° 15' E). The soil in these places is of clay so that rain water was retained in the puddles for several weeks, though they finally dried out in June as a result of the warm sunny weather. Tadpoles gathered in the warmed shallow puddles. In some places, usually at a depth of 1-3 cm below the water level, the floor of the puddle was covered with roundish dish-like pits, 3-4 cm in diameter. Their density was about 530/m<sup>2</sup>. The great majority of the tadpoles was found within the pits, either singly or 2-3 in each pit. From time to time some of the tadpoles moved: they wiggled their tails and simultaneously rotated on a central spot like a magnetic needle of a compass. They thus created a stream of water which washed the whirled up mire over the edge of the pit. Later I observed how in a short time the tadpoles re-shaped the pits, which had been erased by heavy rain or by my own interference when catching tadpoles in the puddle.

As a consequence of the gradual sinking of the water level, parts of the shallow puddles with their pits dried out. The figure shows the part of one dried up creek. All pits in the dried up part of the shallow areas seemed empty of tadpoles which had left them in time. Nevertheless, some smaller puddles dried out completely during June when they included a large number of tadpoles.

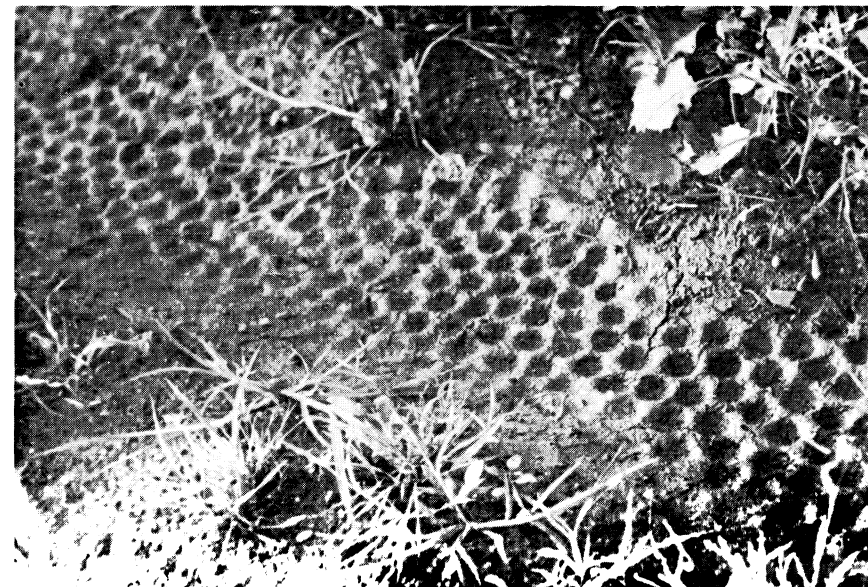

Fig. 1

We may assume that protection against possible drying up was not the tadpoles' main purpose of inhabiting the pits. All the pits were situated in the shallow "coastal" area, whereas the safest place against drying out was the deeper central part of the puddle. It is suggested that the pits create a favourable microclimate, a small, relatively secluded space which is more successfully warmed by the solar radiation.

FIGURE 1. Part of a dried up creek showing pits, which once contained tadpoles.

#### THE CONSERVATION OF BRITISH AMPHIBIANS AND REPTILES—A POLICY

British Herpetological Society—Conservation Committee,  
c/o Zoological Society of London, Regent's Park, London NW1 4RY.

##### GENERAL CONSIDERATIONS AND BACKGROUND

There is an immediate need for action to be taken to conserve the rarer British amphibians and reptiles. These animals do not have a large following of interested amateur naturalists looking after them, as for example do the birds, flowering plants and butterflies. Consequently they have been largely neglected by the conservation movement in this country. Furthermore there are only twelve indigenous species (six reptiles and six amphibians), so the loss or decline of even a single species must be regarded as a serious matter.

The amphibians and reptiles are primitive vertebrates and sensitive to changes in their habitats. Research and observations have shown that their range of movement is extremely limited and their ability to re-colonise areas is very poor. They are subject to considerable collecting pressures and they are not protected by law. There is a great demand for them by dealers, pet-keepers and researchers. As a group, they are not notably aesthetic, nor do they provide any sporting activity (as do fish or other (game) animals). Thus, apart from herpetologists and some sympathetic conservationists, few people make any effort to conserve them. In the case of snakes in particular; because one British species, the Adder, is venomous, all three species of snake and the Slow Worm (a legless lizard) are killed in large numbers.

From the historical information now available about the Sand Lizard, Smooth Snake and Natterjack Toad, it is evident that the number of areas and sites in which they occur has greatly decreased in recent years. In many instances the reasons for their disappearance can, with reasonable confidence, be attributed to such things as severe burning of heathland, draining of ponds, collection and urbanisation. Afforestation and agricultural reclamation usually result in change of habitat which they cannot tolerate. It should be noted that the decline of these species has been generally due to human interference. Moreover, much of the remaining habitat has now been sub-divided in such a severe way that re-colonisation is unlikely to occur, obvious examples being the Dorset and Surrey heaths and the Lancashire sand-dunes, and as the number of colonies of the rare species are further reduced, and become more isolated, the surviving ones become more important and yet increasingly vulnerable.

##### AIMS

The Conservation Committee of the BHS has been created in order to try and rectify the above situation. It has three basic aims:—

1. To gather together and correlate as much information as possible on the past and present distribution of the British amphibians and reptiles and their ecological requirements.
2. Based on this information, to co-operate with the Nature Conservancy, Naturalists' Trusts and others in the conservation of these animals.
3. To take its own initiative in the conservation field in relation to these groups of animals, within the framework of the Nature Conservancy's recently formed \*Working Group on the Conservation of Reptiles and Amphibians.

To implement these aims the BHS Conservation Committee is approaching the problem by action on three fronts. First to try and ensure that all existing important sites are protected as fully as possible; secondly by the management of sites; and thirdly by reviewing the question of re-introductions.

The protection of sites will be achieved wherever possible by providing evidence for the Nature Conservancy and the County Naturalists' Trusts to warrant the inclusion of such sites in National and Local Reserves or as Sites of Special Scientific Interest (SSSI). In other cases, where necessary, a direct approach to owners will be made.

The management of sites will have as its aim both the perpetuation of prime habitat and the enhancement of low status habitat in the key areas. Initially attention has been concentrated on terrestrial sites, which have deteriorated through such things as scrub encroachment. Attention is now being given to amphibian sites which have declined as a result of drying-out. This is caused by such things as reed or grass overgrowth and water abstraction. Management will be pursued to clear out excessive plant growth, deepen old ponds or to create new ponds on suitable sites.

Although priority is being given to the rare species, particular emphasis is being placed on conservation work that will give benefit to as many species as possible e.g. the conservation of mature, dry heath which supports all the six reptiles and three of the amphibians as well as noted bird and invertebrate species.

Although in some cases complete clearance of scrub and trees is desirable for reptile habitats, care has been taken to ensure that certain areas of scrub and a number of trees are left untouched. This is important both from an amenity viewpoint and because of their importance to nesting birds. On heathland, for example, gorse clumps are used by rare or local bird species such as the Dartford Warbler, Red-backed Shrike and Stonechat.

The question of re-introduction has to be considered with great care. It is important to appreciate that the attempted re-introduction of almost any species of plant or animal into almost any area is usually fraught with difficulties. These may not only affect the species being re-introduced, but also the entire ecology of an area. A number of herpetologists have already independently moved species in well intentioned attempts to save colonies and re-establish others. In view of the inherent difficulties and dangers involved with re-introductions and the number of different associations whose interests may be affected, it is obviously to everyone's benefit that any further re-introductions are carried out according to an accepted policy and fully recorded.

The following policy is based on that set down in the Society for the Promotion of Nature Reserves (SPNR) Conservation Liaison Committee's advisory booklet on introductions for nature reserves.

1. The loss of many sites as a consequence of land development is inevitable, but a reasonable dispersal and minimum population of rare reptiles and amphibians should be maintained by conservation measures. Re-introductions may help in this context, as would the re-creation of fresh habitat by mechanical means.

2. Re-introduction is only one of several remedial methods that can be employed, but it can be justifiable in special cases most usually when species are rare and endangered. It is preferable to try to revive an ebbing population by conservation management before resorting to re-introductions.

3. In terms of resource wastage, no remaining survival pocket of these rare species should be needlessly discarded and the collection of individuals of rare species from doomed sites should be carried out and breeding in captivity attempted. The stock can then be used to later re-populate selected sites elsewhere.

4. If a habitat which once contained a viable population of a rare species can be re-created through management, and then the area be protected, it should be considered as a possible re-introduction site. Similarly, even if a site has no past records for a rare species but falls within the known distribution (zone) for that species, it could also be considered as a possible re-introduction site, provided the habitat is (or can easily be made) suitable and provided that the survival of the species within this zone can be shown to be dependent on such an introduction.

5. Flourishing colonies of a particular species should only be used as a source of animals for necessary re-introduction as a last resort and when no other source is available.

6. Regions for the Sand Lizard have already been defined and accepted, and these are applicable to the Smooth Snake. It is also intended to define regions for the Natterjack Toad, and for the Crested Newt.

7. The value of preserving the genetical integrity of local as well as National populations must always be considered. When faced with the prospect of extinction of a species within one of its zones however, exceptions may have to be made. Present opportunities to save British stock should avoid the need to introduce individuals from Continental sources.

8. Controlled experimental release (by marking, keeping records and continued observations) of the rare species to obtain ecological data can have conservational value. It is better to have completed research into the problems associated with the re-introduction of species in advance of the stage actually being reached of the species reaching the verge of extinction.

9. Re-introductions will be carried out in liaison with the \*Working Group which represents the Nature Conservancy, SPNR and County Naturalists' Trusts so that other species of animals and plants, probably unrelated, would not be adversely affected.

\* New arrangements have been suggested whereby the activities of the Group would be divided between the Conservation Committee of the BHS and a new Working Group for the Conservation of Endangered Species. (As noted in the minutes of the Working Group's sixth meeting of 14th September, 1972.)

## LETTERS TO THE EDITOR

In a preliminary survey of the reptiles of the Ibadan area the reptiles of an area within six miles radius of the Ife University campus were listed. When the survey was prepared the existence of another lizard was known but identification difficulties precluded its inclusion. However, it has now been identified as *Panaspis breviceps togoense*, a species apparently widely distributed in West Africa. Therefore the writer feels that this should be added to the survey. This skink was found only within the confines of the Biological Garden of the University, a forest belt, and only in the moist area immediate to a small stream. On no occasion were these skinks observed in strong sunlight. Their frequency may be described as fairly common, but local.

Reference: Blackwell, 1967. A preliminary survey of the reptiles of the Ibadan area. *Br. J. Herpet.* 3.

Family Species	Frequency	Forest	Thickets	Open Areas	Teak Plantation Cocoa farm	Aquatic environs	Gardens	Houses Inselberg
Scincidae	common fairly							
<i>Panaspis breviceps togoense</i>		*						

Kenneth Blackwell,  
41 Charnwood Avenue,  
Westone, Northampton. 3/7/72.

At Moorgate, Wrangaton, South Brent, SX 677593, on June 26th, 1969, a melanistic slow worm was first seen and again on the next two succeeding days. It was found underneath a corrugated iron sheet. It was generally black tending towards a reddish colour underneath but very dark all over. It was not seen again.

At Ivybridge, SX 651568, on September 16th, 1972, another melanistic slow worm was seen, 2½ miles away from the earlier recorded specimen. Likewise the Ivybridge specimen was also underneath corrugated iron. This animal was a very dark mahogany colour, about 7" to 8" long with a stump tail. It was not seen again, although the area was inspected daily by Mrs. M. Y. Hedges thereafter, for several weeks.

Colleagues I have contacted are not familiar with any reports of such melanistic specimens though there are plenty of albinistic ones. They must therefore be particularly rare.

H. G. Hurrell,  
Moorgate, Nr. South Brent,  
Devon, TQ10 9HN. 13/12/72.

## TESTUDO GRAECA (L.) IN TURKEY

While driving through western Anatolia between 24 August and 4 September, 1972, I saw one large swamp terrapin (*Emys orbicularis* (L.)) and nine common tortoises (*Testudo graeca* (L.)) on or beside the road. The tortoises varied in length (along the centre of the carapace), and in breadth, as follows:—

Largest specimen 22.5 cm x 15.5 cm (1.8 kg).

Smallest specimen 16.0 cm x 12.0 cm (0.8 kg).

The absence of smaller tortoises suggests the age structure of a long-lived population with a low rate of recruitment. I did not see any dead animals and the drivers of motor vehicles clearly took pains to avoid tortoises on the road. When I collected one, a Turkish lady told me, in some consternation, "nix essen"! There was no evidence of tortoises being exploited, as they are in Morocco (M. R. K. Lambert, 1969, *Oryx* 10, 161-6), for shepherds and agricultural workers seemed disinterested in them. Populations are also clearly more dense in Turkey since Lambert found only 23 tortoises during 20 days of solid searching, often with Moroccan assistants.

J. L. Cloudsley-Thompson,

Department of Zoology,  
Birkbeck College,  
London WC1E 7HX.  
25/9/72.

## BOOK REVIEWS

DIE TERRARLENTIERE by Günther Nietzsche (1972). Publ. Ulmer, Stuttgart, W. Germany. Vol. 2. pp. 300. 6 Colour Plates, 155 black & white photographs. Price: DM 64.

Volume 1 of this work has been reviewed in this journal in vol. 4 no. 8, June 1971 p. 220.

Volume 2 deals in great detail with the plants suitable for terraria, with suitable foods for crocodiles, lizards and snakes, including force-feeding methods and with the main crocodylian, saurian and ophidian species likely to be offered to the amateur. A further chapter is devoted to the problems of breeding and to the accommodation of reptiles in out-of-door vivaria. The author complains, in his preface that most of his photographs are reproduced in black and white and that it is difficult, if not impossible to type any animal from such pictures however good they may be. In these days of colour film and colour television we can indeed no longer be satisfied with natural history pictures in black & white half tone. Colour may raise the price but it also raises the value of such a book considerably. For those who have a good command of German Dr. Nietzsche's books would be a valuable addition to their library.

E. Elkan.

Published by the British Herpetological Society and

Printed by Fox Publications Limited, London, N.7., England

## INDEX

Volume: 4, Nos. 1-12

AVERY, A.	Preliminary list of parasites collected from reptiles and amphibians in Northern Nigeria. ... ..	217
BANTA, B. H. and MARER, P. J.	An attack by a Solpugid on an Iguanid lizard hatchling ... ..	266
BEEBEE, TREVOR	Mating and spawning of <i>Rana temporaria</i> under unusual circumstances. ... ..	231
BELLAIRS, A. d'A.	See RUBIN, L. and SHEPPARD, LESLEY	
BLACKWELL, K.	<i>Kinixys homeana</i> . ... ..	40
	Eating habits of <i>Kinixys</i> species. ... ..	42
	Note on the Asiatic newt. ... ..	157
BRAZAITIS, PETER J.	Sex determination in living crocodiles. ... ..	54
BONARIC, J. C.	See BONS, J.	
BONS, J. and BONARIC, J. C.	Histology of the egg tooth in the Green Turtle. ... ..	202
BRYANT, S.V.	See RUBIN, L.	
BUSTARD, H. ROBERT	Gekkonid lizards. ... ..	7
	<i>Pygopus nigriceps</i> . ... ..	22
	Reptile tail abnormalities caused by high temperature egg incubation. ... ..	121
	Temperature and water tolerances of incubating sea turtle eggs. ... ..	196
	Temperature and water tolerances of incubating crocodile eggs. ... ..	198
	Loggerhead turtle movements. ... ..	228
CAMPDEN-MAIN, SIMON M.	<i>Calliophis maculiceps</i> subspecies. ... ..	49
CLARK, RICHARD J.	Greek snake collection. ... ..	45
	Herpetofauna of the Argo-Saronic Gulf Islands, Greece. ... ..	185
	<i>Testudo marginata</i> in the Cyclades, Greece. ... ..	188
	Comments on the Aegean 4-lined snake. ... ..	207
	A third collection of reptiles made in Turkey. ... ..	258
	New locality records for Greek reptiles. ... ..	311
CLARK, RICHARD J. and ERICA, D.	Notes on four lizard species from the Peloponnese, Greece. ... ..	135
CLOUDSLEY-THOMPSON, J. L.	Water-relations of the young Nile crocodile. ... ..	107
	Diurnal rhythm of activity in the Nile monitor. ... ..	112
	Transpiration from lizards of the Chihuahuan desert. ... ..	175
	A new record for <i>Uromastix</i> in Sudan. ... ..	177
	Site tenure and selection in the African gecko <i>Tarentola annularis</i> . ... ..	286

COLLIER, R. V.			
Notes on the toad at Castor Hanglands.	...	...	144
CONSERVATION COMMITTEE, B. H. S.			
A policy for the conservation of British amphibians and reptiles.	...	...	239
COOKE, A. S. and FULFORD, W. G.			
Feeding behaviour of a blind warty Newt.	...	...	216
COOPER, JOHN E.			
Snake bite.	...	...	17
Surgery on captive Gaboon viper.	...	...	234
DAVIES, M.			
<i>Anguis fragilis</i> devouring newly-born young.	...	...	20
Frog's unusual defence posture.	...	...	63
DOWLING, H. G. (CHAIRMAN)			
ASIH herpetological catalogue.	...	...	62
DUDA, P. C.			
The venous system of <i>Agama tuberculata</i> .	...	...	297
ELKAN, E.			
Heating small cages for small Amphibia.	...	...	19
The "tailed" frog <i>Ascaphus truei</i> .	...	...	42
Tropical frog post mortem.	...	...	60
Epidermal ulcers in frogs.	...	...	154
Embalming frogs.	...	...	155
Case report on a Corn snake.	...	...	236
The unique defence mechanism of <i>Rhabdophis tigrina</i> .	...	...	307
ERNST, CARL H.			
Observations on the egg and hatchling of the American turtle, <i>Chrysemys picta</i> .	...	...	224
FALCK, JOHN L.			
Longevity of <i>Bombina</i> species.	...	...	43
FEUER, ROBERT C.			
Eggs in urinary bladder of bullfrog.	...	...	214
FULFORD, W. G.			
See COOKE, A. S.			
GARTLAN, J. S. and STRUHSAKER, T. T.			
Habits of the Calabar ground python.	...	...	201
GAYMER, R.			
Seychelles herpetofauna.	...	...	24
GOIN, C. J. and GOIN, OLIVE B.			
Comments on the age of the frog family Pipidae.	...	...	326
GORZULA, S. J.			
Two observations on learning in Anurans.	...	...	332
Defensive behaviour of a captive Colubrid.	...	...	333
HAGSTROM, TORHEL			
Identification of newt specimens.	...	...	321
HARDING, PAUL T.			
The diet of some juveniles of the common toad.	...	...	292
HAZELWOOD, ELLEN			
Study of a breeding colony of frogs in Lancashire.	...	...	96
Frog pond contaminated.	...	...	177
HONEGGER, RENE E.			
The Green turtle in the Seychelles Islands.	...	...	8
HOOGMOED, M. S.			
Mating and early development of <i>Gastrotheca marsupiata</i> .	...	...	1

HUGHES, B.			
Snake killed by plant burr.	...	...	39
JACKSON, OLIPHANT F.			
Snake anaesthesia.	...	...	172
JAEGER, ROBERT G.			
See MUNDEL, PETER.			
JOHN, K. O.			
Musculature of the South Indian flying lizard.	...	...	161
Territorial behaviour in the South Indian flying lizard.	...	...	169
JOY, J. E.			
See MURPHY, J. B.			
KEISER Jr., EDMUND D.			
Unusual specimen of the Neotropical Vine Snake.	...	...	116
LAMBERT, M. R. K.			
Moroccan herpetofauna.	...	...	28
Maltese herpetofauna.	...	...	114
Amphibians and reptiles from S. W. Turkey.	...	...	129
LESTON, DENNIS			
Activity pattern of Night adder in Ghana.	...	...	139
Some snakes from the forest zone of Ghana.	...	...	141
LIMPUS, COLIN			
See BUSTARD, H. ROBERT.			
MARER, P. J.			
See BANTA, B. H.			
MUNDEL, PETER and JAEGER, ROBERT G.			
Notes on the ecology and behaviour of six species of Mexican anurans.	...	...	221
MUNRO, H. O.			
Egg deposition by a Sand lizard.	...	...	20
MURPHY, J. B.			
Removal of a deficient fang mechanism in a captive Puff Adder.	...	...	314
The use of the macrolide tylosin in the treatment of reptilian respiratory infections.	...	...	317
NICKERSON, MAX A.			
Sex determination in snakes.	...	...	138
OPATRYN, EVZEN			
Clay "nests" of toad tadpoles.	...	...	338
PAWLEY, RAY			
Housing "Off Exhibit" reptiles in Brookfield Zoo, Chicago.	...	...	210
PEAKER, M.			
Eating of green algae by gecko.	...	...	38
Deliberate stone swallowing by Mississippi alligator.	...	...	103
PEAKER, MALCOLM and STEPHANIE J.			
Use of lure in noosing small lizards.	...	...	18
Yugoslavian herpetofauna.	...	...	36
Death of a snake while swallowing prey.	...	...	38
RAJABAI, B. S.			
See RAO, M. V. SUBBA.			
RAO, M. V. SUBBA			
Biology of two selected lizards of Tirupati.	...	...	151

RAO, M. V. SUBBA and RAJABAI, B. S.			
Reproduction in the ground lizard, <i>Sitana ponticeriana</i> and the Garden lizard, <i>Calotes nemicola</i> .	...	...	245
Rhythmic activity in ground dwelling Agamid lizard.	...	...	328
RICHES, ROBERT J.			
Notes on a clutch of eggs of viperine snake.	...	...	14
Early maturity in Garter snakes.	...	...	16
RUBIN, L., BELLAIRS, A. d'A. and BRYANT, S. V.			
Congenital malformations in snakes.	...	...	12
SABNIS, J. H.			
<i>Natrix piscator piscator</i> anatomy and histology.	...	...	51
Adrenal structure in <i>Naja naja</i> and <i>Natrix piscator</i> .	...	...	124
SAINT-GIRONS, M-C and H.			
A study of red blood cells in reptiles.	...	...	67
SHEPPARD, LESLEY and BELLAIRS, A. d'A.			
The mechanism of autonomy in <i>Lacerta</i> .	...	...	276
SIMMS, C.			
Crested newt double-brooded in an indoor vivarium.	...	...	43
Declining amphibian breeding at an isolated Yorkshire pond.	...	...	93
Recolonization of burnt heath by lizards.	...	...	117
Shift in a population of Northern Vipers.	...	...	268
SPOCZYNSKA, JOY O. I.			
Rearing hatchling Leatherback Turtles.	...	...	189
Rearing hatchling Green Turtles.	...	...	263
STEWART, J. W.			
Frog and toad arrival at breeding site.	...	...	59
STREET, D. J.			
Notes on the reproduction of the Southern smooth Snake.	...	...	335
STRUHSAKER, T. T.			
See GARTLAN, J. S.			
SUBBA RAO, M. V.			
Biology of two selected lizards of Tirupati.	...	...	151
TARLO, L. B. HALSTEAD			
Squamata classification.	...	...	32
TOYE, S. AFOLABI			
The locomotory activity of the Rainbow lizard, <i>Agama agama</i> (L).	...	...	252
TURNER, S. C.			
Amphibian metamorphosis.	...	...	83
WEBB, R. G.			
The Asiatic Gecko <i>Hemidactylus frenatus</i> in Manzanillo, Mexico.	...	...	267

<i>Aelurolyx seychellensis</i> .	26.
Agama	
<i>agama</i> .	252, 297.
<i>bibroni</i> .	29.
<i>tuberculata</i> .	297.
Algyroides	
<i>moreoticus</i> .	135.
<i>nigropunctatus</i> .	19, 135.
Alligator	
<i>mississippiensis</i> .	54, 103, 109, 125.
<i>sinensis</i> .	54.
<i>Alytes obstetricans</i> .	43.
<i>Ammotrecha californica</i> .	266.
Anguis	
<i>fragilis</i> .	20.
<i>fragilis peloponnesiacus</i> .	135.
<i>Anotheca spinosa</i> .	222.
<i>Ardea cinerea</i> .	9.
<i>Ascaphus truei</i> .	42.
<i>Birgus latro</i> .	9.
Bitis	
<i>arietans</i> .	314.
<i>gabonica gabonica</i> .	234.
<i>Boa constrictor constrictor</i> .	317.
Boaedon	
<i>geometricus</i> .	27.
<i>lineatus</i> .	39.
<i>Bombina salsa</i> .	43.
<i>Brachyura species</i> .	9.
Bufo	
<i>bufo</i> .	6, 125, 144, 292, 332.
<i>bufo bufo</i> .	59.
<i>bufo spinosus</i> .	36, 30.
<i>calamita</i> .	332.
<i>mauritanicus</i> .	30.
<i>melanostictus</i> .	38.
<i>regularis</i> .	332.
<i>viridis</i> .	338.
<i>viridis viridis</i> .	30, 36.
<i>woodhousei</i> .	332.
<i>Caiman sclerops</i> .	107.
<i>Calabria reinhardtii</i> .	201.
<i>Calliophis maculiceps</i> .	49.
Calotes	
<i>nemoricola</i> .	151, 245.
<i>versicolor</i> .	161.
<i>Caranx ignobilis</i> .	9.
Caretta	
<i>caretta</i> .	228, 263.
<i>caretta gigas</i> .	27.
<i>Causus rhombeatus</i> .	139.
<i>Ceratophrys dorsata</i> .	60.
Chalcides	
<i>mionecton mionecton</i> .	30.
<i>ocellatus montanus</i> .	30.
<i>ocellatus subtypicus</i> .	30.
<i>Chamaeleo hohmelli</i> .	169.
Chelonia	
<i>expansa</i> .	121.
<i>mydas</i> .	121, 196, 263.
<i>mydas japonica</i> .	8, 27.
<i>Chrysemys picta</i> .	224.
<i>Clemmys caspica leprosa</i> .	30.
Coronella	
<i>austriaca</i> .	335.
<i>girondica</i> .	30, 335.
<i>Corvus albus</i> .	9.
Crocodylus	
<i>niloticus</i> .	27, 54, 103, 107.
<i>novaegiuneae</i> .	121, 198.
<i>rhombifer</i> .	54.
<i>Dasypeltis scabra</i> .	22.
Demansia	
<i>fraseri</i> .	22.
<i>textilis</i> .	22.
Denisonia	
<i>flagellum</i> .	23.
<i>gouldii</i> .	23.
<i>Dermochelys coriacea</i> .	27, 189.
<i>Diplodactylus vittatus</i> .	169, 287.
<i>Discoglossus pictus pictus</i> .	31.
<i>Draco dussumieri</i> .	16.
Elaphe	
<i>obsoleta obsoleta</i> .	317.
<i>quatuorlineata</i> .	207.
<i>Eleutherodactylus rhodopsis</i> .	223.
<i>Emys orbicularis</i> .	125, 343.
<i>Eremias olivieri olivieri</i> .	30.
Eretmochelys	
<i>imbricata</i> .	263.
<i>imbricata imbricata</i> .	27.
Fregata	
<i>ariel iregalai</i> .	9.
<i>minor aldabrensis</i> .	9.
Gastrotheca	
<i>marsupiata</i> .	1.
<i>ovifera</i> .	1.
Gehyra	
<i>mutilata</i> .	26.
<i>variegata</i> .	7, 287.
<i>Gerrhonotus multicarinatus</i> .	125.
Hemidactylus	
<i>brookii</i> .	39.
<i>frenatus</i> .	26, 267.
<i>mabouia</i> .	26.
<i>Heteronotia binoei</i> .	7, 287.
<i>Holbrookia maculata</i> .	176.
Hyla	
<i>arborea</i> .	1.
<i>arborea arborea</i> .	36.
<i>cinerea</i> .	155.
<i>dendrocarta</i> .	222.
<i>eximia</i> .	223.
<i>marsupiata</i> .	1.
<i>Hyperolius marmoratus</i> .	332.
<i>Hypogeophis species</i> .	25.
<i>Hypopachus oxyrrhinus</i> .	223.
<i>Iguana iguana</i> .	107.
<i>Kassina senegalensis</i> .	332.

- Kinixys*  
  *belliana* 42.  
  *erosa* 40.  
  *homeana* 40.
- Lacerta*  
  *agilis* 65, 127.  
  *dugesii* 276.  
  *lepida pater* 30.  
  *hispanica vaucheri* 29.  
  *melisselensis* 19.  
  *melissellensis fiumana* 37.  
  *muralis* 19.  
  *muralis maculiventris* 36.  
  *perspicillata* 30.  
  *sicula* 19.  
  *sicula campestris* 37.  
  *vivipara* 117, 268, 276.
- Lepidochelys*  
  *kempi* 263.  
  *olivacea* 27.
- Lepidodactylus lugubris* 26.  
*Lucasius damaeus* 169, 287.  
*Lutianus bohar* 9.  
*Lycognathophis seychellensis* 27.
- Mabuya*  
  *quinqetaeniatus* 176.  
  *seychellensis* 26.  
  *wrightii* 26.
- Macrolemys temminchi* 214.  
*Megalixalus seychellensis* 25.  
*Microtus agrestis* 269.
- Naja naja* 124, 125.
- Natrix*  
  *maura* 14, 30.  
  *natrix* 12.  
  *natrix helvetica* 14.  
  *piscator* 124, 125.  
  *piscator piscator* 51.  
  *sipedon* 12.  
  *tessellata* 14.
- Nesomantis thamasseti* 25.
- Oedura ocellata* 7, 121, 287.  
*Ophiomorus punctatissimus* 135.  
*Ophisaurus apodus* 37, 135.  
*Oxybelis aeneus* 116.
- Pachymedusa dacinicolor* 221.  
*Panaspis breviceps togoense* 342.  
*Pelomedusa galeator* 237.  
*Pelusios subniger* 27.
- Phelsuma*  
  *laticauda* 38.  
  *species* 26.
- Phoenicopterus ruber antiquorum* 9.  
*Phrynosoma cornutum* 176.  
*Phyllodactylus inexpectatus* 26.  
*Pipidae family* 326.
- Psammmodromus algirus* 29.  
*Pseudemys scripta* 107.  
*Ptyas mucosus* 38.  
*Pupalia lappacea* 39.
- Pygopus*  
  *bayleyi* 22.  
  *lepidopodus* 22.  
  *nigricep* 22.
- Python sebae* 17.
- Quedenfeldtia trachyblepharus* 30.
- Rana*  
  *catesbeiana* 214.  
  *esculenta* 43.  
  *esculenta ridibunda* 30.  
  *mascareniensis* 26.  
  *pipiens* 84.  
  *ridibunda* 332.  
  *temporaria* 2, 64, 83, 231, 268, 271, 332.  
  *temporaria temporaria* 53.
- Rattus norvegicus* 9.  
*Rhabdophis tigrina* 307.  
*Rhinocheilus lecontei* 333.
- Sauromelus obesus* 107.  
*Scelotes species* 26.  
*Sitana ponticeriana* 151, 245, 328.  
*Sooglossinae species* 25.  
*Stenodactylus stenodactylus* 7.
- Tarentola*  
  *annularis* 176, 286.  
  *mauritanica deserti* 30.  
  *mauritanica mauritanica* 30.
- Terrapene carolina* 107.
- Testudo*  
  *gigantea* 27.  
  *graeca* 343.  
  *marginata* 188.
- Thamnophis*  
  *elegans elegans* 16.  
  *sauritus sauritus* 16.  
  *sirtalis sirtalis* 16.
- Threskiornis aethiopica abbotti* 9.
- Triturus*  
  *cristatus* 216, 323.  
  *cristatus laurentus* 43.  
  *pyrrhogaster* 157.  
  *vulgaris* 323.  
  *vulgaris meridionalis* 36.
- Typhlops braminus* 27.
- Uromastix hardwickii* 297.
- Varanus niloticus* 108, 176.  
*Vipera berus* 268.
- Xantusia vigilis* 125.  
*Xenopus laevis* 83, 127.