

SPECIES DISTINCTION AND RELATIONSHIPS OF THE WESTERN IBERIAN *PODARCIS* LIZARDS (REPTILIA, LACERTIDAE) BASED ON MORPHOLOGY AND MITOCHONDRIAL DNA SEQUENCES

D. J. HARRIS¹ AND P. SÁ-SOUSA²

¹ Centro de Estudos de Ciência Animal (CECA/UP), Campus Agrário de Vairão, Portugal

² Centro de Ecologia Aplicada, Universidade de Évora, 7002-544, Évora, Portugal

Wall lizards (*Podarcis*) are the dominant reptile group across most of southern Europe. Their taxonomy is complex because most species exhibit substantial intraspecific morphological polymorphisms. We have estimated the phylogeny of the particularly diverse western Iberian forms using partial cytochrome oxidase and cytochrome *b* mitochondrial DNA sequence data and have compared this against morphological variation. Of the two currently recognized species in the area – *Podarcis hispanica* and *P. bocagei* – neither is monophyletic, and extremely high genetic diversity between newly identified forms (up to 15% cytochrome *b* divergences) indicates that both are species complexes. *Podarcis b. bocagei* is genetically distinct from *P. (b.) carbonelli* which appears to be a separate species using both mtDNA and protein electrophoretic data. The insular form previously assigned to *P. b. berlengensis*, and sometimes argued to deserve species status is not genetically distinct from *P. (b.) carbonelli* using the mtDNA sequences. *P. hispanica* can be separated into at least four highly divergent groups, two in western Iberia, one in eastern Iberia and one in North Africa.

Key words: phylogeny, cytochrome *b*, cytochrome oxidase, morphology, Iberian lizards

INTRODUCTION

On the Iberian Peninsula three species of insectivorous wall lizards have been recognized – the Iberian wall lizard, *Podarcis hispanica* Steindachner 1870; Bocage's wall lizard, *Podarcis bocagei* Seoane 1884; and *Podarcis muralis* Laurenti 1768. *Podarcis bocagei* and *P. hispanica* live in sympatry in large areas of NW Iberia (Galán, 1986; Pérez-Mellado & Galindo, 1986; Sá-Sousa, 1995a). Both exhibit pronounced sexual dimorphism, adult males being larger than females and having more intense colour patterns (Galán, 1986; Pérez-Mellado & Galindo, 1986).

Podarcis hispanica is a medium sized (SVL 65-70 mm), morphologically variable rock-dwelling lizard, which is found in SW France (Langedoc-Rousillon and Cévennes), the Iberian Peninsula (except the northernmost corner) and NW Africa (Galán, 1986; Guillaume, 1987, 1997). Despite taxonomic controversy about *P. hispanica* subspecies, two forms have been recognized in Portugal (Sá-Sousa 1995a, 2000a). First, there is a NW Iberian form (*P. hispanica* type 1) that resembles the "lusitanica" form of Guillaume (1987). *P. hispanica* type 1 is found in Galicia, in the 'Submeseta Norte' plateau, in the northern half of Portugal and on the 'Sistema Central' mountain range (Sá-Sousa, 2000a). In Portugal, *P. hispanica* type 1 seems to inhabit mainly highlands (>400 m) where either Atlantic or continental climatic conditions may prevail. It has been found in the northern part of Portugal, north of the Tagus river

(Sá-Sousa, 2000a). *P. hispanica* type 1 has the following characteristics: flattened head and body; either reticulated or striped dark dorsal patterns; and whitish-pearly coloured belly (for details see Pérez-Mellado, 1981a,b; Galán, 1986; Pérez-Mellado and Galindo, 1986; Guillaume, 1987; Sá-Sousa, 1995a).

P. hispanica type 2 (SW Iberian form) has been found in Andalusia, in Extremadura, in the Madrid region, and in the western and southern parts of Portugal (Sá-Sousa, 2000a). In Portugal, *P. hispanica* type 2 seems to prefer lowlands (<400 m) with a Mediterranean climate (Sá-Sousa, 2000a). This form has the following characteristics: head and body moderately robust; green and/or light brown patterns, and yellow-orange belly (see Klemmer, 1957; Salvador, 1986; Guillaume, 1987; González de la Vega, 1989; Sá-Sousa, 1995a). Given several records of *P. hispanica vaucheri* in SW Iberia (Boulenger, 1905; Klemmer, 1957; Salvador, 1974, 1986; Busack, 1986; Guillaume, 1987) one might hypothesize that morphologically *P. hispanica* type 2 and *P. hispanica vaucheri* are the same. However, we retain the *P. hispanica* type 2 denomination until further studies confirm whether similarity in phenotype corresponds to a common genotype across the entire range. So far all allopatric greenish morphotypes of wall lizard found in the southern part of Iberia (e.g. southern Portugal, Andalusia and Levant) have been considered as *P. h. hispanica* (Pérez-Mellado, 1998). Also *P. hispanica* type 2 is often mistaken for *P. b. bocagei*, because of their green or light-brown chromatic patterns, although the species show several differences and have allopatric distributions (Sá-Sousa, 1995a, 1998, 2000a).

Correspondence: D. J. Harris, Centro de Estudos de Ciência Animal (CECA/UP), Campus Agrário de Vairão, 4480 Vila do Conde, Portugal. E-mail: james@mail.icav.up.pt

Podarcis b. bocagei is a medium-sized (adult snout-vent length, SVL=65-70 mm), ground-dwelling lizard, the males of which show green dorsal patterns, while females are brown with a pair of green stripes (Galán, 2000; Pérez-Mellado, 1981*a,b*, 1986; Sá-Sousa, 1995*a*). This species is an Iberian-Atlantic endemic occurring in W Asturias, Cantabria, Galicia and north of Portugal (Galán, 1986, 1997; Sá-Sousa, 1998). On a coarse scale, the distribution of *P. b. bocagei* can be largely explained by macroenvironmental variables and type of climate (Sá-Sousa, 2000*b*).

It has been suggested that *P. b. carbonelli* Pérez-Mellado 1981 merits species distinction (Sá-Sousa, in prep.; Sá-Sousa *et al.* 2000). *P. b. carbonelli* (SVL=50-55 mm) is a small, green ground-dwelling lizard, initially thought to be restricted to the W Sistema Central range (Pérez-Mellado, 1981*a,b*, 1986). However, it has been found in other mountain systems as well as along the Atlantic lowlands, particularly in Portugal (Magraner, 1986; Sá-Sousa, 1995*b*, 1999, 2000*b*).

There, the type of climate – but also the balance between the number of frost days per year and the degree of aridity – appear important to explain the distribution of *P. b. carbonelli* (Sá-Sousa, in prep.).

Morphological characters and the existence of parapatric zones of contact between different types (i.e. without interbreeding) suggested that *P. bocagei* and *P. hispanica* might in fact be species complexes (Sá-Sousa, 2000*a* and in prep.). To resolve relationships between and within these groups, and to determine whether recognized clades based on morphological characters are genetically distinct, a phylogenetic analysis was conducted using DNA sequences derived from two mitochondrial genes, cytochrome *b* and cytochrome oxidase I. Populations across the range of the accepted subspecies of *P. bocagei* were sampled. For the cytochrome *b* data sets previously published sequences of *P. hispanica* from eastern Spain and Morocco (Castilla *et al.*, 1998; Harris & Arnold, 1999) were included in the analyses.

TABLE 1. List of lizards examined in the mtDNA phylogeny. * indicates previously published data was included in the analysis. Sequences are deposited in Genbank (accession numbers AF372051 to AF372089). Map codes are shown in Fig. 1.

Species	mtDNA Code	Locality	COI/ Cyt <i>b</i>	Map Code
<i>Gallotia galloti</i>		Gran Canaria	1/-	
<i>Lacerta dugesii dugesii</i>		Madeira	1/*	
<i>Lacerta perspicillata</i>		Mallorca	-/*	
<i>Podarcis hispanica</i> 'liolepis'		Castellón, Spain	-/*	
<i>Podarcis hispanica</i> "type 1"	<i>P.h.1</i>	Vila Real, Pt.	1/1	B
	<i>P.h.2</i>	Montesinho, Pt.	1/-	A
	<i>P.h.3</i>	Montesinho, Pt.	1/-	A
<i>Podarcis hispanica</i> "Moroccan"	<i>P.h.m1</i>	High Atlas, Morocco	-/1	T
	<i>P.h.m2</i>	High Atlas, Morocco	1/1	T
	<i>P.h.m3</i>	High Atlas, Morocco	1/1	T
<i>Podarcis hispanica</i> "type 2"	<i>P.h.v1</i>	Leiria, Pt.	1/-	C
	<i>P.h.v2</i>	Portalegre, Pt.	1/1	D
	<i>P.h.v3</i>	Beja, Pt.	1/1	E
	<i>P.h.v4</i>	Marvao, Pt.	1/-	F
	<i>P.h.v5</i>	Águeda, Pt.	1/-	G
<i>Podarcis bocagei bocagei</i>	<i>P.b.b1</i>	Montesinho, Pt.	1/-	A
	<i>P.b.b2</i>	Montesinho, Pt.	1/-	A
	<i>P.b.b3</i>	Vila Pouca d Aguiar, Pt.	1/-	K
	<i>P.b.b4</i>	Serra do Gerês, Pt.	1/-	H
	<i>P.b.b5</i>	Vairão, Pt.	1/-	J
	<i>P.b.b6</i>	Vairão, Pt.	1/1	J
	<i>P.b.b7</i>	Vairão, Pt.	1/1	J
	<i>P.b.b8</i>	Braga, Pt.	1/-	I
	<i>P.b.b9</i>	Viana do Castelo, Pt.	1/-	L
	<i>P.b.b10</i>	Viana do Castelo, Pt.	1/-	L
	<i>P.b.b11</i>	Viana do Castelo, Pt.	1/1	L
<i>Podarcis carbonelli carbonelli</i>	<i>P.c.c1</i>	Serra da Estrela, Pt.	1/1	M
	<i>P.c.c2</i>	Torreira, Aveiro, Pt.	1/1	N
	<i>P.c.c3</i>	Monte Clérigo, Pt.	1/1	Q
	<i>P.c.c4</i>	Peniche, Pt.	1/-	P
<i>Podarcis carbonelli berlengensis</i>	<i>P.c.b.</i>	Berlenga isle, off Peniche	1/-	O

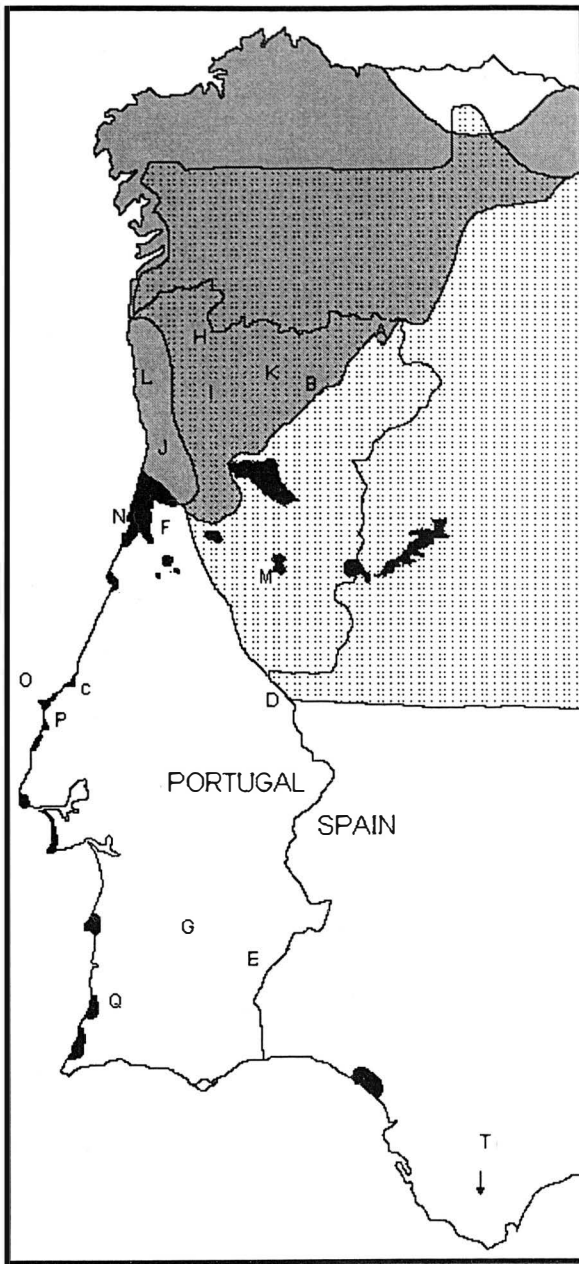

FIG. 1. Map showing the sampling localities used for the mtDNA analysis. The ranges of *P. hispanica* 1 (stippled), *P. b. bocagei* (grey) and *P. (b.) carbonelli* (black) are shown. *P. hispanica* 2 is found in the region south of *P. hispanica* 1, but the complete extent of its range is unknown.

MATERIALS AND METHODS

LABORATORY PROCEDURES

Localities of the lizards from which DNA was extracted and/or biometric characters were scored are given in Table 1. Tissue samples consisted of tail tips stored in 100% ethanol. Voucher specimens are kept at the University of Évora. Total genomic DNA was extracted from tail tissue using standard methods (Sambrook *et al.*, 1989). Polymerase Chain Reaction (PCR) primers used in both the amplification and the sequencing were cytochrome *b1* and *b2* (Kocher *et al.*, 1989) and CO1e and CO1f (Palumbi, 1998). These

amplified regions of approximately 350 bp and 550 bp respectively. Thermocycling consisted of 30 cycles of 93°C for 30 secs, 55°C for 1 min and 72°C for 1 min, followed by a single cycle at 72°C for 5 min. Successful PCR bands were purified using a QIAEX II kit (Quiagen) and sequenced on an Applied Biosystems Model 373A DNA Sequencing System, using a PRISM Ready Reaction DyeDeoxy Terminator Cycle Sequencing kit. Centrisep spin columns (Princeton Separations Inc.) were used for excess dye extraction.

PHYLOGENETIC ANALYSES

Sequences were aligned using Clustal W (Thompson *et al.*, 1994). There were no insertions or deletions. They were then imported into PAUP* (Swofford, 2001) for phylogenetic analyses. When estimating phylogenetic relationships among sequences, one assumes a model of evolution regardless of the optimality criteria employed. Determining which model to use given one's data is a statistical problem (Goldman, 1993). We used the approach outlined by Huelsenbeck and Crandall (1997) to test alternative models of evolution, employing PAUP* and Modeltest (Posada & Crandall, 1998). A starting tree was obtained using neighbour-joining. With this tree, likelihood scores were calculated for various models of evolution and compared using a chi-square test, with degrees of freedom equal to the difference in free parameters between the models being tested. The null hypotheses tested in this way included: (1) nucleotide frequencies are equal; (2) transition rates are equal to transversion rates; (3) transition rates are equal; (4) transversion rates are equal; (5) rate homogeneity within the data set; and (5) no significant proportion of invariable sites (Table 2). Once a model of evolution was chosen, it was used to estimate a tree using maximum likelihood. Ten replicate heuristic searches were made with random sequence addition. Confidence in resulting nodes was assessed using the bootstrap technique (Felsenstein, 1985) with 1000 replicates. Genes were analysed separately and in combination.

BIOMETRICS

Eleven biometric variables were obtained from 12 females and 24 males from each of 20 populations (exact localities available on request), using 0.05 mm callipers (see procedure in Pérez-Mellado & Gosá, 1988): (1) snout-vent length; (2) head length; (3) head width; (4) inter-orbital width; (5) frontal width; (6) inter-nasal width; (7) head depth; (8) orbital depth; (9) frontal depth; (10) nasal depth; and (11) hind limb length (Fig. 2). Sexes were analysed separately. Squared Mahalanobis distance between centroids was used since it takes into account the correlations among biometric variables and is independent of the relative scales of the various variables (Legendre & Legendre 1998). UPGMA clustering was applied to the distance matrix to assess the lizard phenetic relationships (Rohlf, 1993; Sokal & Rohlf, 1995).

TABLE 2. Tests of hypotheses relating to the model of evolution appropriate for phylogeny reconstruction (Huelsenbeck & Crandall, 1997). *P*-values were obtained with Modeltest (Posada & Crandall, 1998). For each hypothesis the data set with cytochrome oxidase (top), cytochrome *b* (middle) and then with the combined regions (below) is tested. Due to the performance of multiple tests, the significance level of rejection of the null hypothesis was adjusted via the Bonferroni correction to $\alpha=0.01$.

Null hypothesis	Models compared	$-\ln L_0$	$-\ln L_1$	df	<i>P</i>
Equal nucleotide frequencies	H_0 : JC69, H_1 : F81	2035	2009	3	0.000
		1558	1509		0.000
		2843	2822		0.000
Equal <i>t_i</i> and <i>t_v</i> rates	H_0 : F81, H_1 : HKY85	2009	1907	1	0.000
		1509	1439		0.000
		2822	2684		0.000
Equal <i>t_i</i> rates	H_0 : HKY85, H_1 : TrN	1907	189	1	0.000
		1439	1425		0.000
		2684	2684		0.581
Equal <i>t_v</i> rates	H_0 : TrN, H_1 : TIM	1896	1896	1	0.275
		1425	1425		0.322
		H_0 : HKY85, H_1 : K81uf	2684		2684
Equal rates among sites	H_0 : TrN, H_1 : TrN+G	1896	1817	1	0.000
		1425	1357		0.000
		H_0 : HKY85, H_1 : HKY85+G	2684		2591
Proportion of invariable sites	H_0 : TrN+G, H_1 : TrN+G+i	1817	1817	1	0.999
		1357	1355		0.057
		H_0 : HKY85+G, H_1 : HKY85+G+i	2591		2589

RESULTS

Twenty-six individuals from 15 populations of *P. hispanica* or *P. bocagei* were sequenced for the cytochrome oxidase gene. The closely related *L. dugesii* (Harris *et al.*, 1998) was sequenced as an outgroup, and the sequence from the more distantly related *Gallotia galloti* was also included in the analyses. The most appropriate model of evolution for this data set was the Tamura Nei model (TrN) model with a discrete approximation of a gamma distribution of variable sites (base frequencies A: 0.31, C: 0.16, G: 0.24, T: 0.29, equal transversion ratios and A/G 13.8, C/T 8.3, gamma shape parameter 0.18 - Table 2). Using this model, a ten replicate heuristic search found a single most likely tree, with a log likelihood of -1811 (Fig. 3A). Twelve individuals from nine populations were also sequenced for the cytochrome *b* gene. This was combined with four previously published sequences for *P. hispanica* (Harris & Arnold, 1999), and two additional outgroups, *Lacerta dugesii* and *L. perspicillata*. For this data set the most appropriate model of evolution was again the TrN model with a discrete approximation of a gamma distribution of variable sites (base frequencies A: 0.26, C: 0.29, G: 0.13, T: 0.32, equal transversion ratios and A/G 3.5, C/T 9.7, gamma shape parameter 0.26 - Table 2). Using this model, a ten replicate heuristic search found a single most likely tree, with a log likelihood of -1348 (Fig. 3B). Since both genes are mitochondrial and therefore inherited as a single locus, a combined analysis was also carried out. *L. dugesii* was used as the outgroup, and 12 indi-

viduals of *P. hispanica* or *P. bocagei* were included. For this data set the most appropriate model of evolution was the HKY model (transition/transversion ratio of 4.99) with a discrete approximation of a gamma distribution of variable sites (Table 2). Using this model, a ten replicate heuristic search found a single most likely tree, with a likelihood of -2586 (Fig. 3C). This ML-based hypothesis of relationships was compared against two alternatives, with *P. bocagei* monophyletic, and *P. hispanica* monophyletic respectively, and other relationships unrestrained. Using the same model of evolution, ten replicate heuristic searches found short-

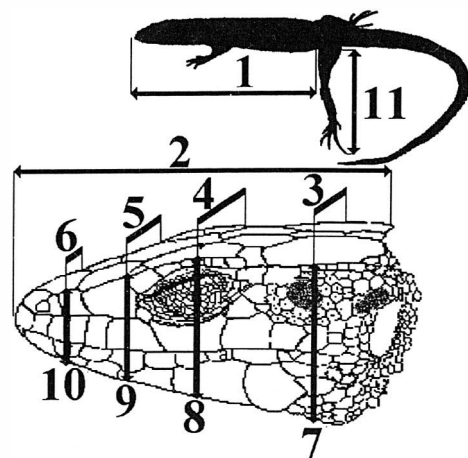
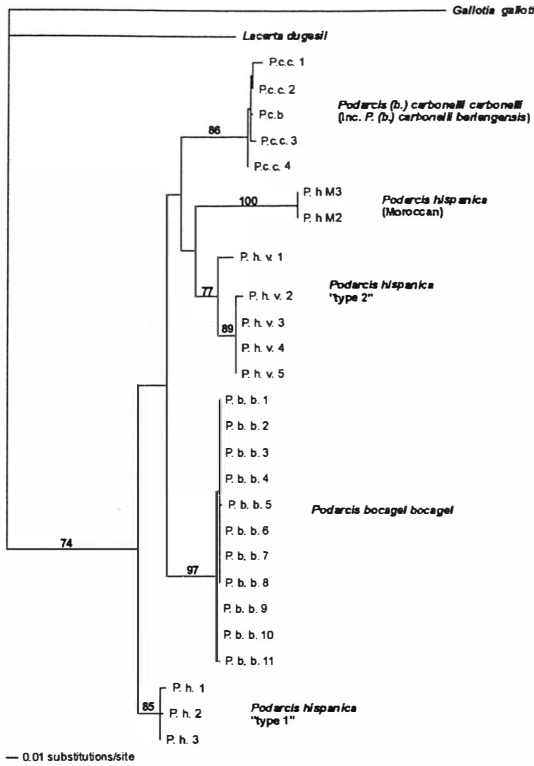
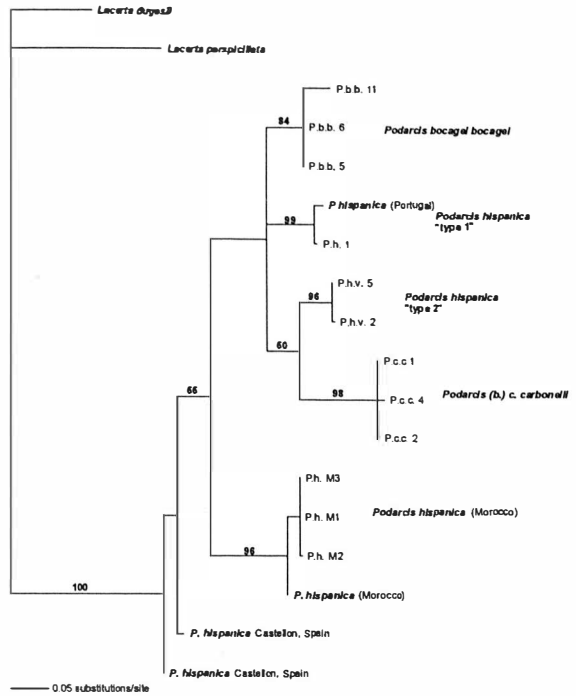

FIG 2. The 11 biometric variables used in the analysis. 24 males and 12 females from each of 19 populations were measured, including all four mainland morphotypes.

A



B



C

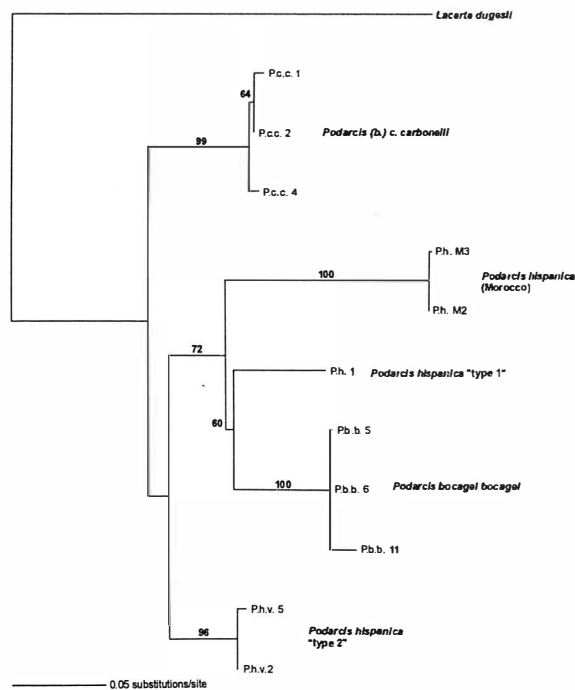

FIG. 3. A, maximum likelihood tree derived from cytochrome oxidase sequences. The tree was rooted using *Gallotia galloti* and *Lacerta dugesii* as outgroups. Numbers above nodes indicate bootstrap support (1000 replicates). B, maximum likelihood tree derived from cytochrome *b* sequences. The tree was rooted using previously published sequences of *L. perspicillata* and *L. dugesii* sequences as outgroups. Numbers above nodes indicate bootstrap support (1000 replicates). C, maximum likelihood tree derived from combined cytochrome *b* and cytochrome oxidase sequences. The tree was rooted using *L. dugesii* as an outgroup. Numbers above nodes indicate bootstrap support.

TABLE 3. Maximum-Likelihood Tests (Shimodaira & Hasegawa, 1999) of alternative tree topologies for *Podarcis* lizards. Trees compared were the maximum likelihood tree based on the combined DNA sequence data (Fig. 2C), and those based on alternative hypotheses where either *Podarcis bocagei* or *Podarcis hispanica* are monophyletic. **P* is the probability of obtaining a more extreme t-value under the null hypothesis of no difference between trees. Both these hypotheses show significantly decreased fit relative to the maximum likelihood tree.

Tree	Log likelihood	Δ Log likelihood	* <i>P</i>
Max. likelihood tree	-2586	-	-
Monophyletic <i>P. bocagei</i>	-2598	12	0.029
Monophyletic <i>P. hispanica</i>	-2599	13	0.021

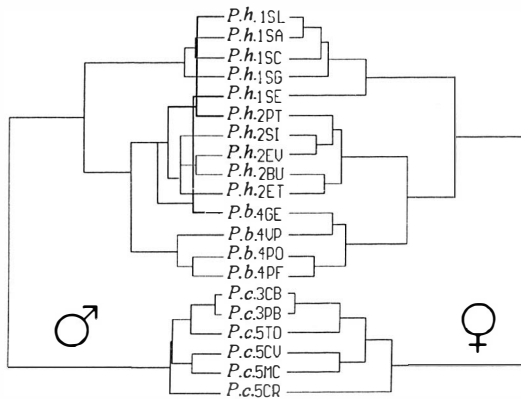

FIG. 4. UPGMA cluster analysis of the biometric variables. Included are *P. hispanica* type 1 (*P.h.* 1) and type 2 (*P.h.* 2), *P. bocagei* (*P.b.*) and *P. (b.) carbonelli* (*P.c.*). Separation of the four forms is effective in the females, but less so in the males.

est trees of $-\ln 2599$ and $-\ln 2598$ respectively. These were compared against the ML tree with the likelihood variance test of Shimodaira and Hasegawa (1999) using 1000 RELL bootstraps. Both were significantly less likely (Table 3).

The UPGMA trees derived from the morphological data show that each major cluster corresponds to one of the four forms of wall lizard (Fig. 4). Clear separation is found in females, while some populations of males belonging to one group cluster with other forms. *P. bocagei bocagei* clusters with *P. hispanica* type 2; both grouped in the next step with *P. hispanica* 1; and finally, *P. bocagei carbonelli* is the most dissimilar.

DISCUSSION

The reciprocal monophyly of the designated subspecies *P. b. bocagei* and *P. (b.) carbonelli*, is strongly supported by the mtDNA analysis. Specimens from across the ranges form monophyletic groups in all

analyses and bootstrap support is strong, especially in the combined analysis – 99% for *P. (b.) carbonelli*, 100% for *P. b. bocagei*. The degree of genetic differentiation between *P. b. bocagei* and *P. (b.) carbonelli* is high: 9–9.6% between the CO1 sequences and 13.5–15.5% between the cytochrome *b* sequences. The mean cytochrome *b* genetic distance for congeneric reptile species is 13.6% (Harris, in press), and lower levels of CO1 divergence in the iguanian lizards of the genus *Tropidurus* have been used to recommend species candidates (Frost *et al.*, 1998). Further, within these two groups genetic distances are very low – 0–0.06% within *P. (b.) bocagei* and 0.004–0.09% within *P. (b.) carbonelli*. Maintenance of the present taxonomic system is further complicated by the rejection of *P. bocagei* monophyly using both morphological and molecular data. We recommend raising *P. (b.) carbonelli* to species status, following Sá Sousa *et al.* (2000) using protein electrophoretic data.

P. b. berlengensis shows no genetic differentiation from mainland *P. carbonelli* using the CO1 sequence data, and so should be referred to as *P. c. berlengensis*. This has previously been suggested based on the low genetic distance found between these groups, $D=0.08$ (Sá Sousa *et al.*, 2000). *P. c. berlengensis* does show some distinct morphological features primarily associated with an increased mean body size (Vicente, 1985). A similar case has been shown for *Gallotia simonyi simonyi* and *G. s. machadoi*, where an extinct subspecies from a small island showed no difference in mtDNA sequences from the mainland form, despite morphological differences (Carranza *et al.*, 1999). It is, however, markedly different from the example of *Podarcis atrata* from the Columbretes Islands, where inter-island cytochrome *b* divergence is high (Castilla *et al.*, 1998). Much has been made of the expected decrease in genetic diversity of organisms on small islands, and the associated increased risks of extinction. Given the large numbers of insular subspecies of *Podarcis* lizards (nearly 300; Böhme, 1986), it is important to determine which of these phenomena is more common.

Subspecies-level taxonomy within *P. hispanica* has been controversial. Some authors accept one subspecies in Iberia, *P. h. hispanica* and one in North Africa, *P. h. vaucheri* (e.g. Pérez-Mellado, 1986, 1998). Others argue that *P. h. vaucheri* is also found in the southern Iberian Peninsula, and more separate forms within the Iberian Peninsula are to be recognized, though as yet with undetermined taxonomic status (e.g. Guillaume, 1987, 1997). Electrophoretic analyses have given conflicting results – Busack (1986) found a low genetic distance ($D=0.07$) between Andalusian and Moroccan populations of *P. hispanica*, while Capula (1997) suggests they are well differentiated ($D=0.237$), and could represent sibling species.

Our analyses support the conclusions of Sá-Sousa (2000a) that *P. hispanica* in Portugal is composed of

two genetically distinct clades. However the southern form (either *P. hispanica* type 2 or *P. hispanica vaucheri*) is also distinct from the population sampled from Morocco. Whether there are multiple cryptic African species, as has been suggested – based on immunological data (Joger & Bischoff, 1989) cannot be assessed from the present data. It is clear, however, that *P. hispanica* taxonomy needs to be reassessed – our data indicate that *P. hispanica* is made up of multiple genetically distinct clades that do not form a monophyletic group relative to *P. bocagei* and *P. carbonelli*. Additional data from nuclear loci will be needed to confirm this finding based on mtDNA, and to determine whether introgression occurs. Only extensive sampling across the remainder of the range, especially central and eastern Spain and North Africa will allow a more appropriate assessment of the status of these clades.

ACKNOWLEDGEMENTS

D. J. Harris and P. Sá-Sousa were supported by grants from Fundação para a Ciência e Tecnologia (FCT) Praxis XXI –BD/5268/95, PRAXIS/P/BIA/11174/1998 and POCTI/34547/BSE/2000. We are very grateful to P. Celio Alves and J. Teixeira for assistance in collecting samples. Thanks to J. W. Arntzen, N. Ferrand and two reviewers for helpful comments on an earlier draft of this manuscript.

REFERENCES

- Böhme, W. (1986). Handbuch der Reptilien und Amphibien Europas, 3, Weisbaden: Akademische Verlagsgesellschaft.
- Boulenger, G. A. (1905). A contribution to our knowledge of the varieties of the wall lizard (*Lacerta muralis*) in Western Europe and North Africa. *Trans. Zool. Soc. London* **17**, 351-436.
- Busack, S. D. (1986). Biogeographic analysis of the herpetofauna separated by the formation of the Strait of Gibraltar. *Nat. Geogr. Res.* **2**, 17-36.
- Capula, M. (1997). Genetic divergence and phylogenetic inferences in the genus *Podarcis*. In: Roček, Z. & Hart, S. (Eds). Abstracts of the Third World Congress of Herpetology, Prague.
- Carranza, S., Arnold, E. N., Thomas, R. H., Mateo, J. A. & Lopez-Jurado, F. (1999). Status of the extinct giant lacertid lizard *Gallotia simonyi simonyi* (Reptilia: Lacertidae) assessed using mtDNA sequences from museum specimens. *Herpetol. J.* **9**, 83-86.
- Castilla, A. M., Fernandez-Pedrosa, V., Harris, D. J., Gonzalez, A. Latorre, A. & Moya, A. (1998). Mitochondrial DNA divergence suggests that *Podarcis hispanica atrata* from the Columbretes Islands merits specific distinction. *Copeia* **1998**, 1037-1040.
- Felsenstein, J. (1985). Confidence limits on phylogenies: an approach using the bootstrap. *Evolution* **39**, 783-791.
- Frost, D. R., Crafts, H. M., Fitzgerald, L. A. & Titus, T. A. (1998). Geographic variation, species recognition, and molecular evolution of cytochrome oxidase 1 in the *Tropidurus spinulosus* complex (Iguania: Tropiduridae). *Copeia* **1998**, 839-851.
- Galán, P. (1986). Morfología y distribución del género *Podarcis* Wagler, 1830 (Sauria, Lacertidae) en el noroeste de la Península Ibérica. *Rev. Esp. Herp.* **1**, 87-142.
- Galán, P. (1997). *Podarcis bocagei* (Seoane, 1884). Lagartija de Bocage, lagartixa-de-Bocage, lagartixa galega. In *Distribución y biogeografía de los anfibios y reptiles en España y Portugal*. pp. 237-239 J. M Pleguezuelos (Ed.). Granada, Monográfica Tierras del Sur, Univ. Granada and Asoc. Herpetol. Española.
- Galán, P. (2000). Females that imitate males: dorsal coloration varies with reproductive stage in female *Podarcis bocagei* (Lacertidae). *Copeia* **2000**, 819-825.
- Goldman, N. (1993). Simple diagnostic statistical tests of models of DNA substitution. *J. Mol. Evol.* **37**, 650-651.
- González de la Vega, J. P. (1989). Anfibios y reptiles de la provincia de Huelva. Huelva: Imprenta Jiménez, S.L.
- Guillaume, C.-P. (1987). Les petits lacertidés du Bassin Méditerranéen Occidental (genera *Podarcis* et *Archaeolacerta* essentiellement). Doctoral thesis. Montpellier, Univ. Sciences et Techniques du Languedoc.
- Guillaume, C.-P. (1997). *Podarcis hispanica* (Steindachner, 1870). In *Atlas of amphibians and reptiles in Europe*, pp. 278-279. J. P. Gasc et al. (Eds.) Paris, Mus. Nat. Hist. Nat. Paris and Soc. Europ. Herpetol. (SEH).
- Harris, D. J. (in press). Reassessment of comparative genetic distance in reptiles from the mitochondrial cytochrome *b* gene. *Herpetol. J.* in press.
- Harris, D. J. & Arnold, E. N. (1999). Relationships and evolution of wall lizards, *Podarcis* (Reptilia, Lacertidae) based on partial mitochondrial DNA sequences. *Copeia* **1999**, 740-754.
- Harris, D. J., Arnold, E. N. & Thomas, R. H. (1998). Relationships of the lacertid lizards (Reptilia: Lacertidae) estimated from mitochondrial DNA sequences and morphology. *Proc. R. Soc. London B.* **265**, 1939-1948.
- Huelsenbeck, J. P. & Crandall, K. A. (1997). Phylogeny estimation and hypothesis testing using maximum likelihood. *Ann. Rev. Ecol. Syst.* **28**, 437-466.
- Joger, U. & Bischoff, W. (1989). Erste Ergebnisse einer herpetologischen Forschungsreise nach Nordwest-Afrika. *Tier und Museum, Bonn* **1**, 99-106.
- Klemmer, K. (1957). Untersuchungen zur Osteologie und Taxonomie der europäischen mauereideschen. *Abh sencenb. naturforsch. ges.* **496**, 1-56.
- Kocher, T. D., Thomas, W. K., Meyer, A., Edwards, S. V., Pääbo, S., Villablanca, F. X. & Wilson, A. C. (1989). Dynamics of mitochondrial DNA evolution in animals: amplification and sequencing with conserved primers. *Proc. Nat. Acad. Sc., USA* **86**, 6196-6200.

- Legendre, P. & Legendre, L. (1998). Numerical ecology. Amsterdam, Elsevier.
- Magraner, J. (1986). Nouvelle donnée sur la répartition de *Podarcis bocagei carbonelli* (V. Pérez-Mellado, 1981), (Sauria, Lacertidae), dans la Péninsule Ibérique et observations sur son écologie à Doñana (Andalousie, Espagne). *Bull. Soc. Herp. Fr.* **38**, 6-12.
- Palumbi, S. R. (1998). Nucleic Acids II: The Polymerase Chain Reaction. In *Molecular Systematics* pp 205-247. D. M. Hillis, C. Moritz and B. K. Mable (Eds.). Sinauer Associates, Sutherland, MA.
- Pérez-Mellado, V. (1981a). La lagartija de Bocage, *Podarcis bocagei* (Seoane, 1884): primeros datos sobre su distribución, colorido y ecología. *Amphibia-Reptilia* **1**, 253-268.
- Pérez-Mellado, V. (1981b). Nuevos datos sobre la sistemática y distribución de *Podarcis bocagei* (Seoane, 1884) (Sauria, Lacertidae) en la Península Ibérica. *Amphibia-Reptilia* **2**, 259-265.
- Pérez-Mellado, V. (1986). *Podarcis bocagei* (Seoane, 1884). Nordwestiberische Mauereidechse. In *Handbuch der Amphibien und Reptilien Europas* vol. 2/II Sauria, pp. 15-24. W. Böhme, W. (Ed.). Wiesbaden, Aula-Verlag.
- Pérez-Mellado, V. (1998). *Podarcis hispanica* (Steindachner, 1870). In *Reptiles*, 258-272. Salvador, A. (Coord.) *Fauna Iberica*, vol. 10. Ramos, M.A. et al. (Eds.) Madrid: Museo Nacional de Ciencias Naturales (CSIC).
- Pérez-Mellado, V. & Galindo, M. P. (1986). Sistemática de *Podarcis* (Sauria, Lacertidae) ibéricas y norteafricanas mediante técnicas multidimensionales. *Sér. Manuales Universitarios, Univ. Salamanca*, Salamanca.
- Pérez-Mellado, V. & Gosá, A. (1988). Biometria y folidosis en Lacertidae (Sauria, Reptilia). Algunos aspectos metodológicos. *Rev. Esp. Herpetol.* **3**, 105-119.
- Posada, D. & Crandall, K. A. (1998). Modeltest: testing the model of DNA substitution. *Bioinformatics* **14**, 817-818.
- Rohlf, F. (1993). NT-SYS-pc. Numerical taxonomy and multivariate analysis system. version 1.8. Setauket (New York): Exeter Software.
- Sambrook, J. Fritsch, E. F. & Maniatis, T. (1989). *Molecular Cloning: A Laboratory Manual*. Cold Spring Harbour Press, New York.
- Sá-Sousa, P. (1995a). Distinção das lagartixas do género *Podarcis* em Portugal. *Folha Herpetológica (SPH)* **5**, 4-6.
- Sá-Sousa, P. (1995b). Coastland distribution of the Bocage mountain lizard, *Podarcis bocagei carbonelli* in Portugal. *Abstrs. II International Congress on the Lacertids of the Mediterranean Basin*, Olhão, Portugal, 25-30 April.
- Sá-Sousa, P. (1998). Distribución de la lagartija *Podarcis b. bocagei* en Portugal. *Bol. Asoc. Herpetol. Esp.* **9**, 2-4.
- Sá-Sousa, P. (1999). New data on the distribution of *Podarcis bocagei carbonelli* Pérez-Mellado, 1981 in Portugal. *Herpetozoa* **12**, 87-90.
- Sá-Sousa, P. (2000a). A predictive distribution model for the Iberian wall lizard (*Podarcis hispanicus*) in Portugal. *Herpetol. J.* **10**, 1-11.
- Sá-Sousa, P. (2000b). Distribución de la lagartija *Podarcis carbonelli* en Portugal. *Bol. Asoc. Herpetol. Esp.* **11**, 12-16.
- Sá-Sousa, P., Almeida, A. P., Rosa, H. D., Vicente, L. & Crespo, E. G. (2000). Genetic and morphological relationships of the Berlenga wall lizard (*Podarcis bocagei berlengensis*: Lacertidae). *J. Zool. Syst. Evol. Research* **38**, 95-102.
- Salvador, A. (1974). Guía de los anfibios y reptiles españoles. ICONA, Madrid.
- Salvador, A. (1986). *Podarcis hispanica* (Steindachner, 1870) - Iberische Mauereidechse. In *Handbuch der Amphibien und Reptilien Europas* vol. 2/II Sauria, pp. 71-82. W. Böhme, W. (Ed.) Wiesbaden, Aula-Verlag.
- Shimodaira, H. & Hasegawa, M. (1999). Multiple comparisons of log-likelihoods with applications to phylogenetic inference. *Mol. Biol. Evol.* **13**, 964-969.
- Sokal, R. R. & Rohlf, F. J. (1995). Biometry, 3rd ed. New York, W. H. Freeman.
- Swofford, D. L. (2001). PAUP*: *Phylogenetic Analysis using Parsimony (and Other Methods)* 4.0b5. Sinauer Associates, Sunderland, Massachusetts, USA.
- Thompson, J. D., Higgins, D. G. & Gibson, T. J. (1994). Clustal W: improving the sensitivity of progressive multiple sequence alignment through sequence weighting, position specific gap penalties and weight matrix choice. *Nucl. Acid. Res.* **22**, 4673-4680.
- Vicente, L. A. (1985). Description d'une nouvelle sous-espèce de *Podarcis bocagei* (Seoane, 1884) (Sauria, Lacertidae) de l'île de Berlenga: *Podarcis bocagei berlengensis*. *Bull. Mus. natn. Hist. nat., Paris, 4^e sér.* **7(A)**, 267-274.

Accepted: 30.4.01